

North Hudson Sewerage Authority CSO Long Term Control Plan

Public Meeting #2

1. Greetings and Introductions
2. NJDEP Long Term Control Plan Requirements and Ongoing Activities
3. Introduction to CSO Control Strategies and Alternatives
4. Development and Evaluation of Alternatives
5. Review of CSO Control Alternatives
6. Next Steps

May 20, 2019

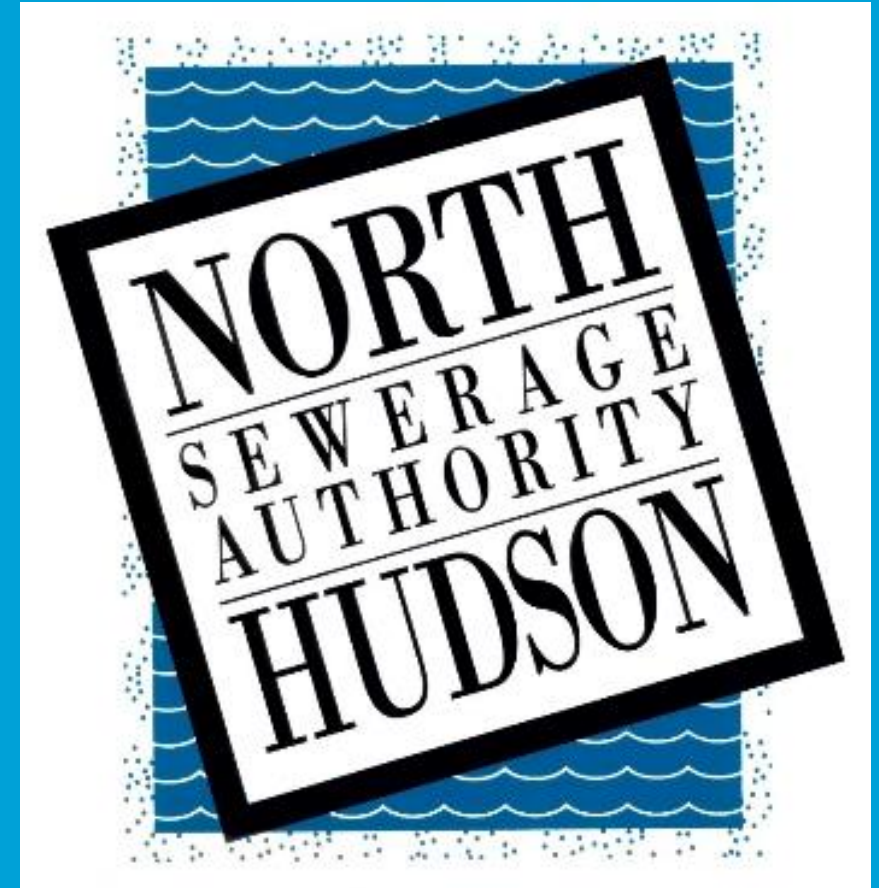

Greetings and Introductions

(Please do sign in)

NJDEP Long Term Control Plan Requirements and Ongoing Activities

NJPDES LTCP Permit Requirements Met via a Series of Activities and Submittals to the NJDEP by June 1, 2020:

- System Characterization (Work Plans and Reports) – July 1, 2018 ✓
- Baseline Compliance Monitoring (Work Plans and Reports) – July 1, 2018 ✓
- Public Participation Process (Report) – July 1, 2018 ✓
- Identification and Consideration of Sensitive Areas (Report) – July 1, 2018 ✓
- Develop and Evaluate CSO Control Alternatives (Report) – July 1, 2019
- Select Alternatives and Plan Implementation of the LTCP (Report) – June 1, 2020

Performed as a LTCP Program with a Consultant Program Manager and a series of projects performed by the Authority's Engineering Consultants

Where Are We on Developing the LTCP?



- Work Plans
- Field Work
 - Condition Assessment
 - Sewer Flow Monitoring
 - CSO Water Quality (WQ) Monitoring
 - Hudson River WQ Monitoring
- Identify Sensitive Areas
- Engineering
 - Land Use and Drainage Analyses
 - Hydraulic Sewer Modeling
 - Hudson River WQ Modeling
- Public Participation
- Reports

- Establish CSO Reduction Targets
- Identify Opportunities with Communities to Reduce CSOs
- Identify and Evaluate CSO Control Strategies and Technologies
- Estimate Potential Project Costs
- Assess Cost/Performance for Potential Projects
- Assess Financial Capability
- Identify Funding Mechanisms
- Report

- Select Strategies and Controls
- Select Funding Mechanisms
- Develop Schedule for Implementation
- Finalize LTCP
- Report

Introduction to CSO Control Strategies and Alternatives

Combined Sewer System and CSOs

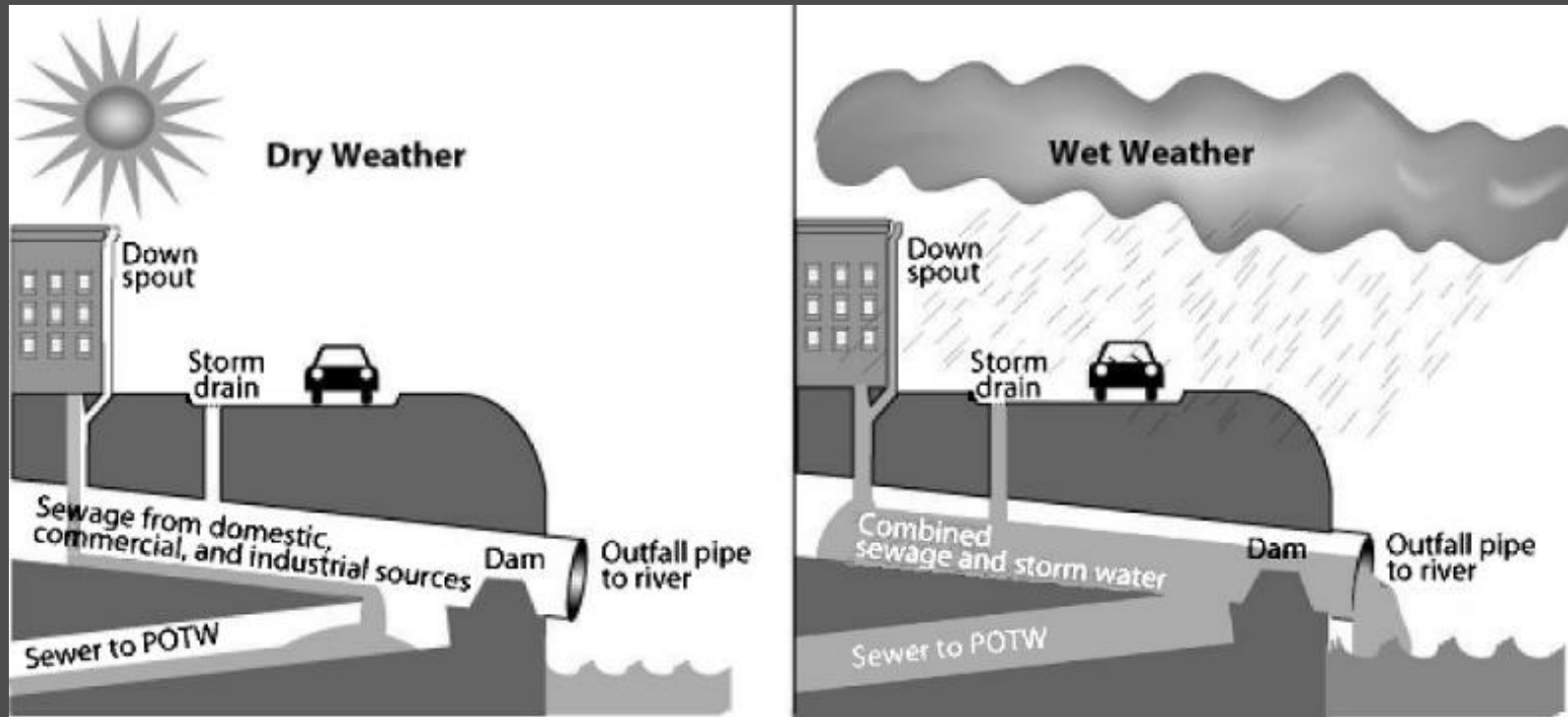

A combined sewer system (CSS) collects rainwater runoff, domestic sewage, and industrial wastewater into one pipe. Under normal conditions, it transports all of the wastewater it collects to a sewage treatment plant for treatment, then discharges to a water body. The volume of wastewater can sometimes exceed the capacity of the CSS or treatment plant (e.g., during heavy rainfall events or snowmelt). When this occurs, untreated stormwater and wastewater, discharges directly to nearby streams, rivers, and other waterbodies.

Development and Evaluation of Alternatives

- As specified in the NJPDES permits from the New Jersey Department of Environmental Protection, an evaluation of combined sewer overflow (CSO) control technologies at each outfall in the service area is required.
- The goal of identifying, developing and evaluating CSO control technologies is to identify the best strategy to reduce the frequency of overflows to no more than 4 at each outfall in a typical year.
- An evaluation of alternatives for the Adams Street WWTP, River Road WWTP and the CSO outfalls in each service area has been developed.
- The purpose of this evaluation is to submit an approvable report to NJDEP in June that provides the information needed for the Authority to then develop the Long Term Control Plans by next summer.

NJDEP CSO Controls to Evaluate

- Green infrastructure
- Increased storage capacity in the collection system
- STP expansion and/or storage
- I/I reduction
- Sewer separation
- Treatment of the CSO discharge
- CSO related bypass of the secondary treatment portion of the STP

Alternatives Analysis

Storage: Subsurface Storage Tanks, In-Line Storage



Truman School in New Haven, CT
CSO Storage Tank beneath parking lot

Alternatives Analysis

Storage: Subsurface Storage Tanks, In-Line Storage



CSO Tunnel
Milwaukee, WI



Alternatives Analysis

Conveyance: Additional Pipeline to Convey to WWTP



Siphon
Alameda, CA



Alternatives Analysis

Green Infrastructure: Adding pervious area to collect stormwater prior to entering combined sewer system, preventing overflow



Rain Garden

Onondaga County



Green Roof

Onondaga County

Alternatives Analysis

Inflow/Infiltration: Lining aging sewers to prevent groundwater from infiltrating into the combined sewer system



H1 Outfall Lining
Hoboken, NJ

Alternatives Analysis

Sewer Separation: Construct storm sewers to collect stormwater that would otherwise enter combine sewer system and contribute to overflow



New York City constructing storm sewers in Coney Island

<https://www1.nyc.gov/site/ddc/about/press-releases/2016/pr-080316-storm-sewers-coney-island.page>

Alternatives Analysis

WWTP Upgrades: Increase capacity at WWTP and combine with conveyance



River Road WWTP
West New York, NJ

Development and Evaluation of Alternatives

Development and Evaluation of Alternatives



Development and Evaluation of Alternatives



- Alternatives Workshop

- In June 2018, a Workshop was held by consultants and the Authority to conceptualize possible control technologies in each drainage area.
- Results of the System Characterization (June 2018) were referenced to estimate the target volume in each drainage area. This provided a baseline for potential size, alignment, and cost of each alternative.

Development and Evaluation of Alternatives

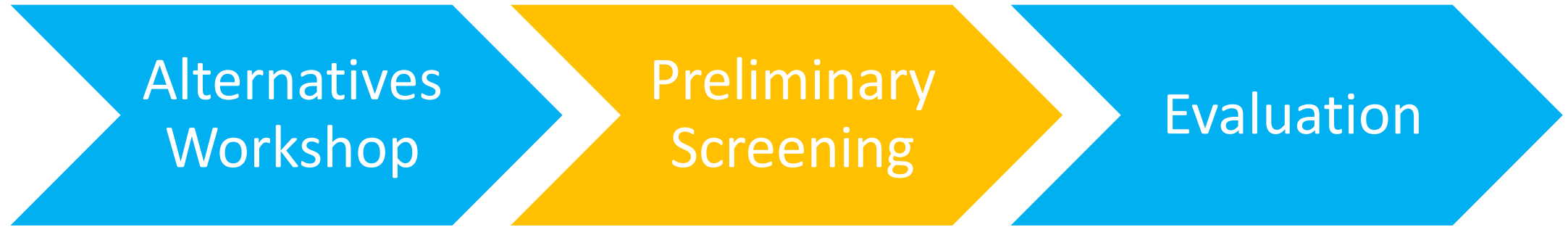

- Preliminary Screening

- Based on results of the Alternatives Workshop and conversations with the Authority, a Preliminary Screening was conducted to eliminate alternatives that either would not meet the goal of 4 overflows per year or could not be constructed due to various obstacles including land ownership, disruptive construction, and high costs.

Development and Evaluation of Alternatives



- Evaluation

- After the list of alternatives for evaluation was finalized, the concept was constructed in the Infoworks model to simulate the potential amount of overflows expected with implementation of the alternative.
- After reaching the target control, conceptual cost estimates were developed.
- Accuracy range of costs: -20% to -50% on the low end, +30% to +100%
- Costs presented here serve as an estimate and are subject to change based on required facilities

Review of CSO Control Alternatives

Alternatives Evaluations - Adams Street

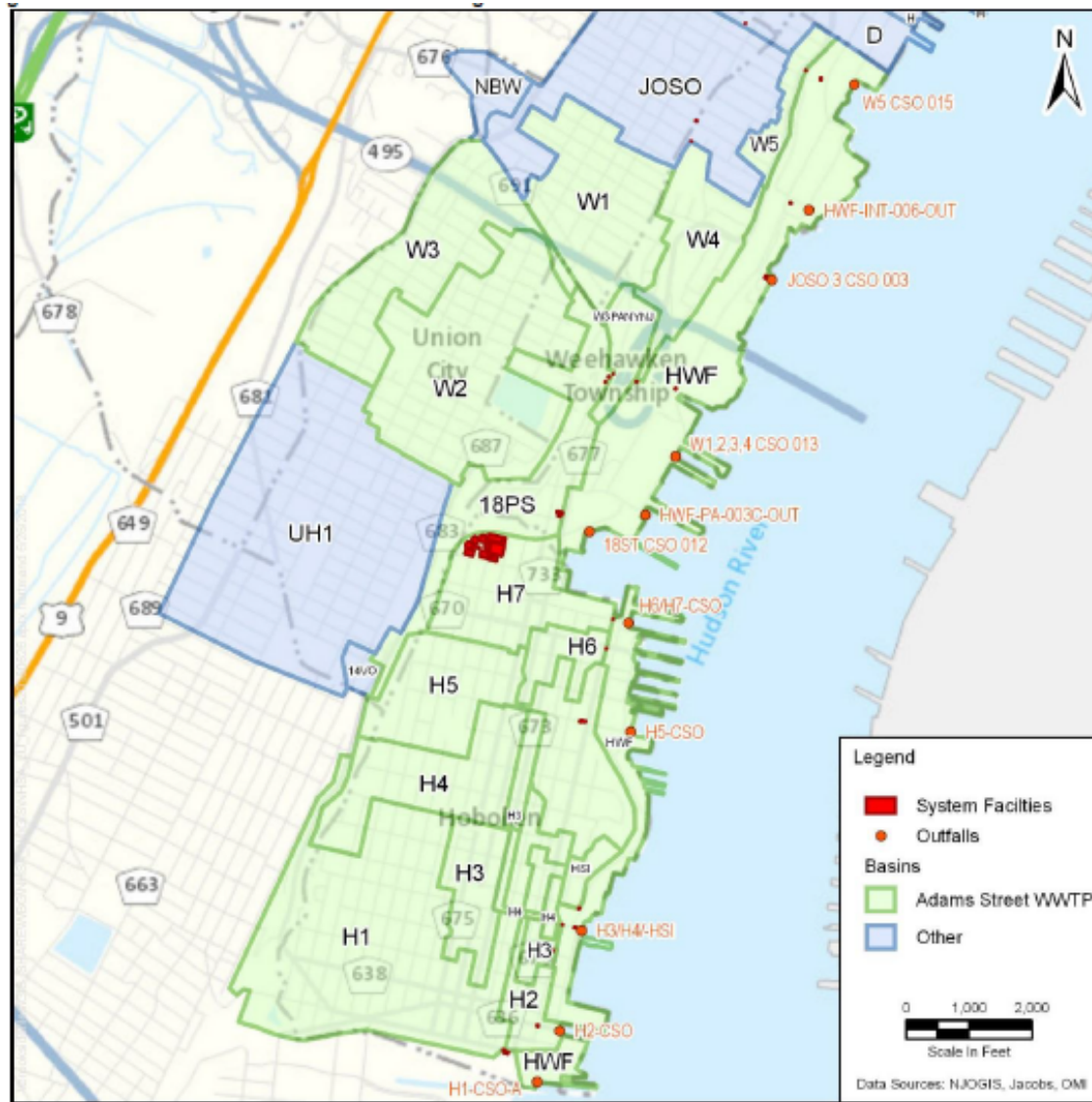

#

Adams Street Combined Sewer System Performance for a Typical Year

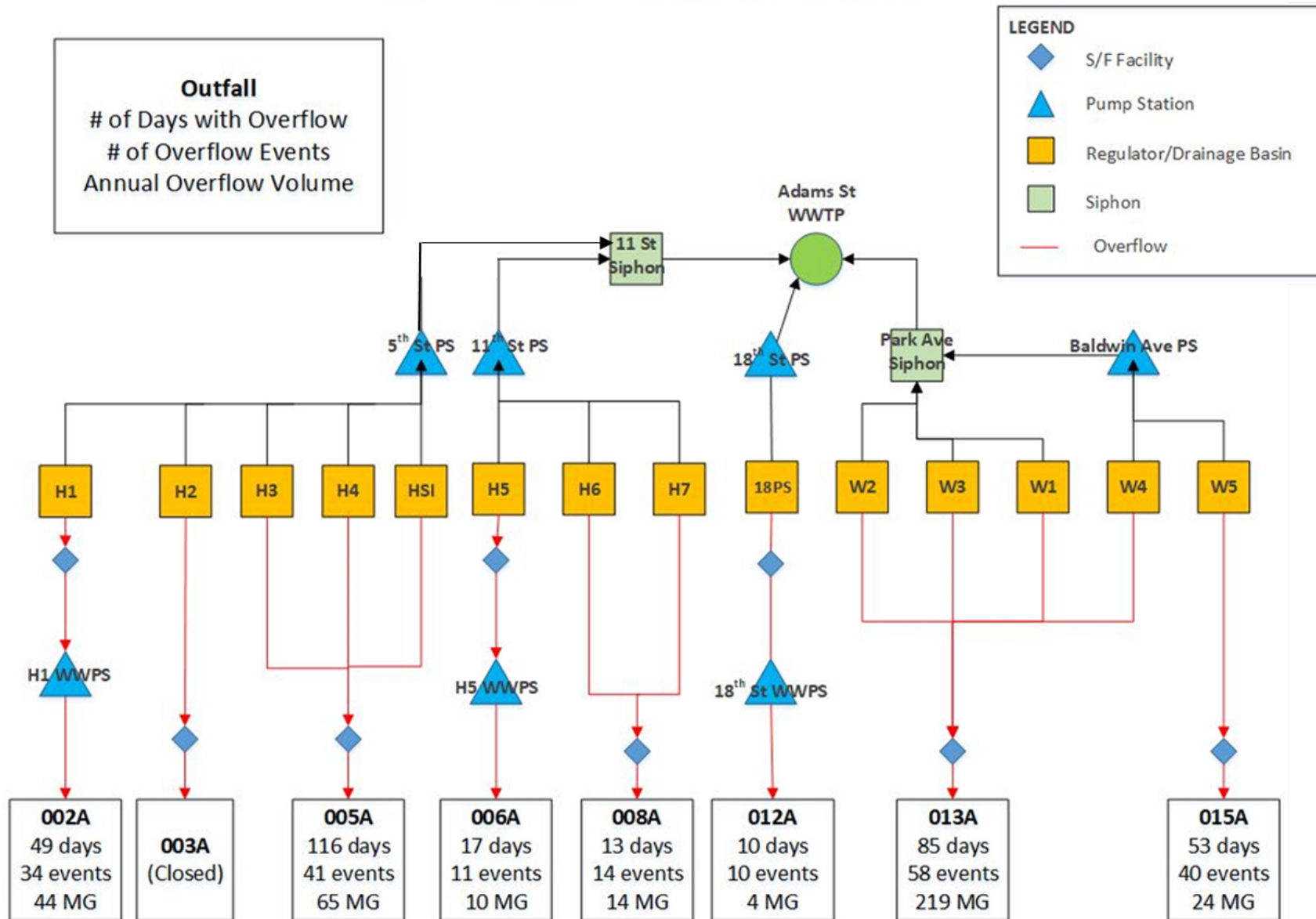

Outfall 002A (Southwest Hoboken)

Alternatives

- **Storage:**

- CSO Storage Structure Lot at Observer Highway and Hudson Street

- **Disinfection:**

- Combine Flows with Jersey City CSO in Long Slip Canal
- Cloth/Compressible Media Filtration

Outfall 002A (Southwest Hoboken)

Overflow Volume

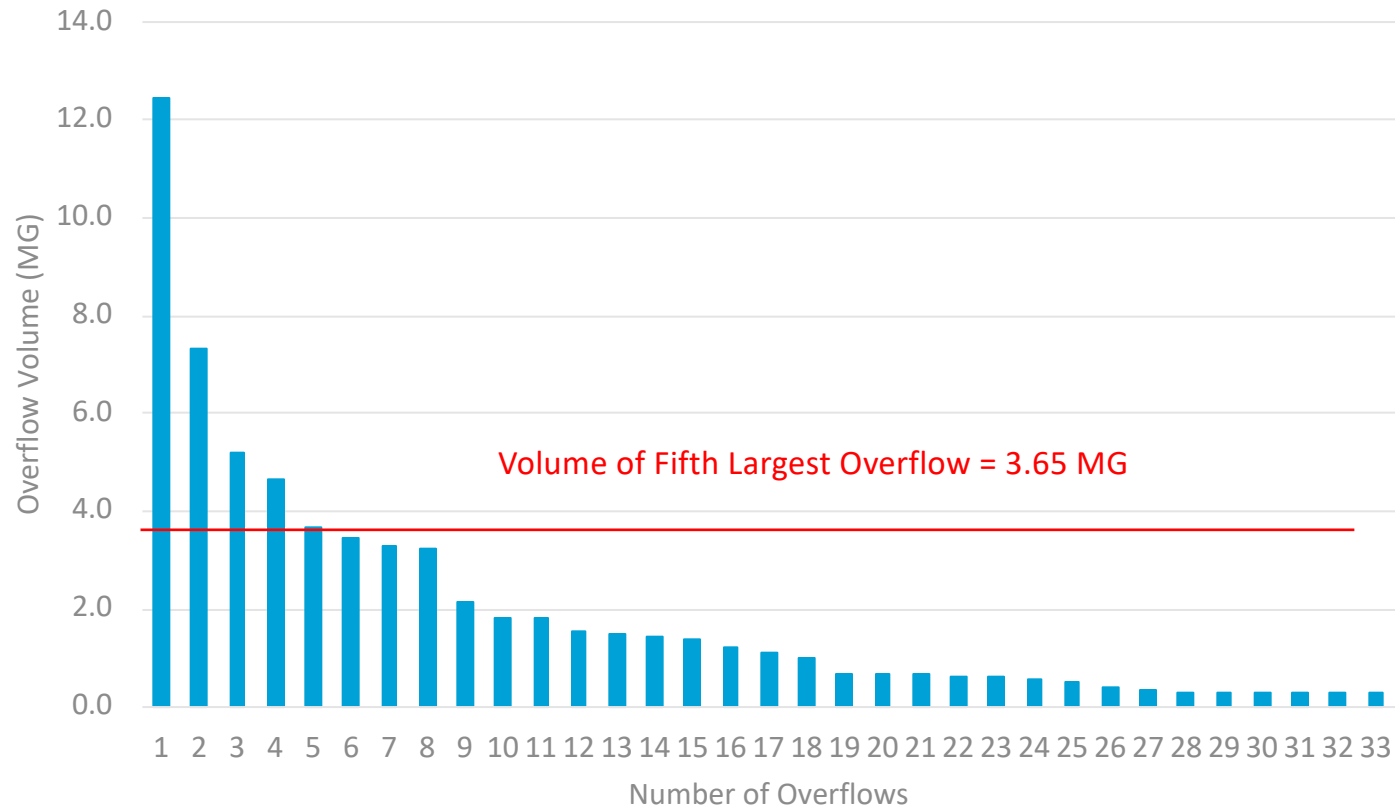

Outfall 002A

CSO Storage Structure at Lot at Observer Highway and Hudson Street

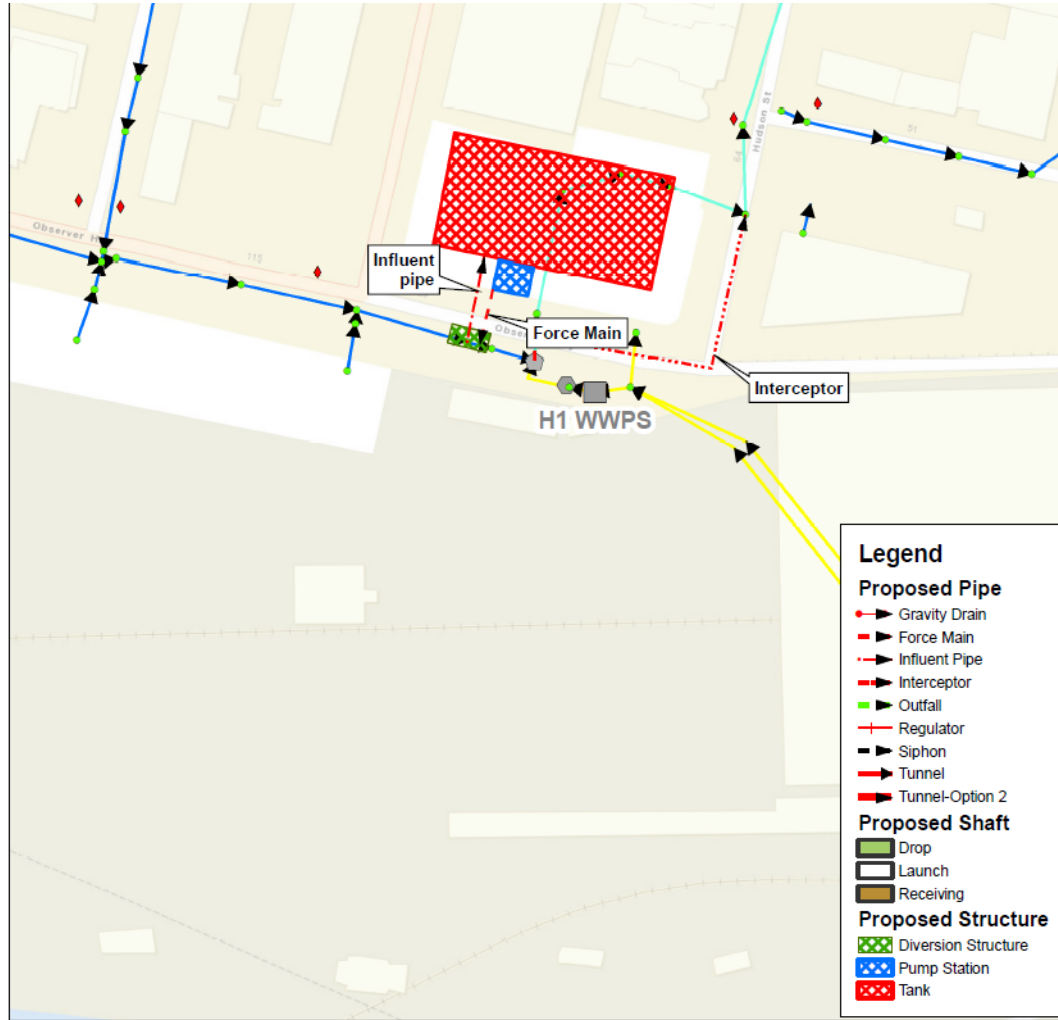

Combine Flows with Jersey City CSO in Long Slip Canal

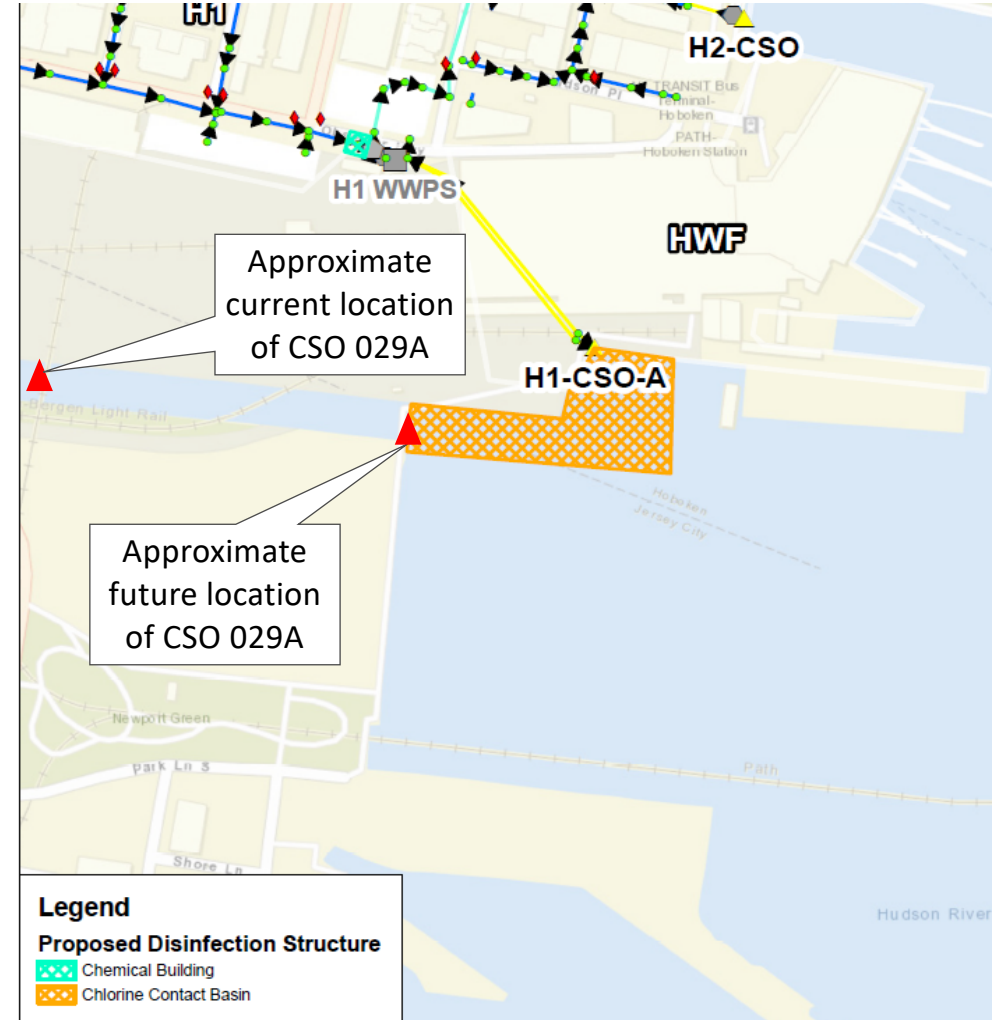

Outfall 002A

Cloth Media Filtration

- **Aqua Prime**
 - Cloth media filtration utilizes cloth woven or fiber pile construction for 10 micron TSS removal
 - Benefits to this type of implementation is the discs are vertically oriented to reduce the required footprint and have higher solids and hydraulic loading rates than other technologies

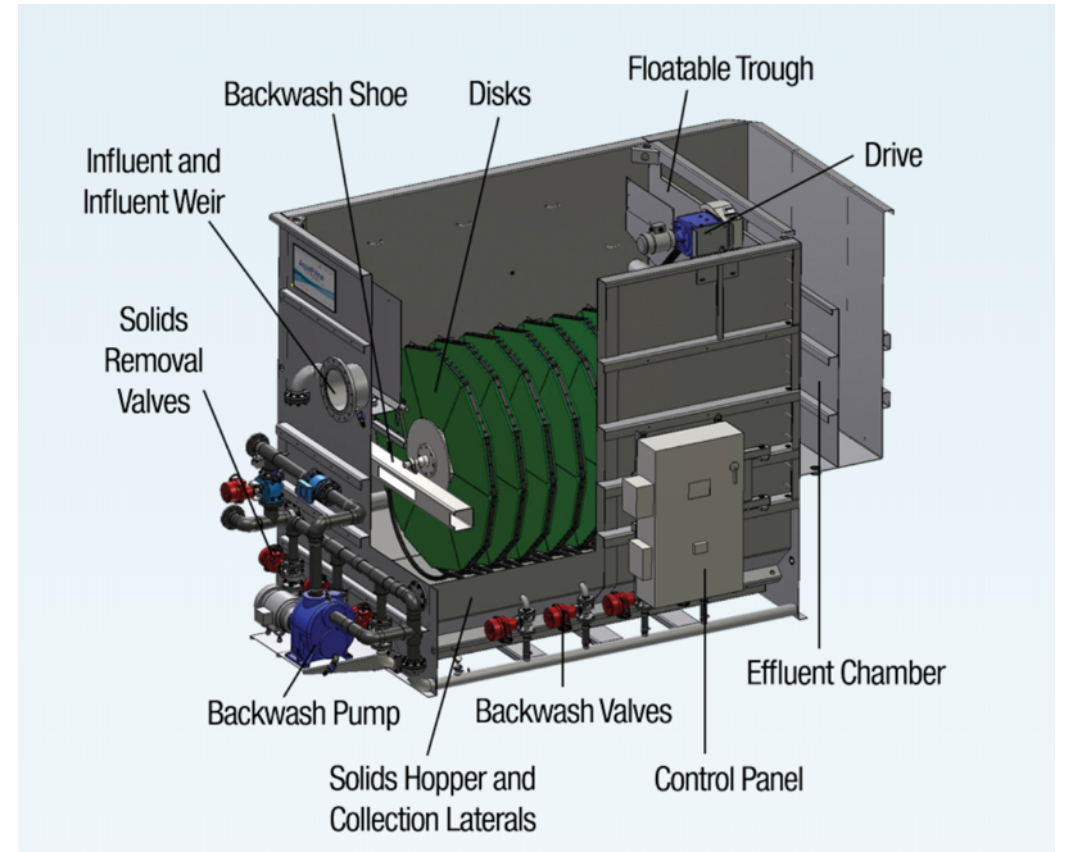

Outfall 002A

Cloth Media Filtration

- Costs can vary dependent on TSS concentration which will be tested should this alternative be selected.

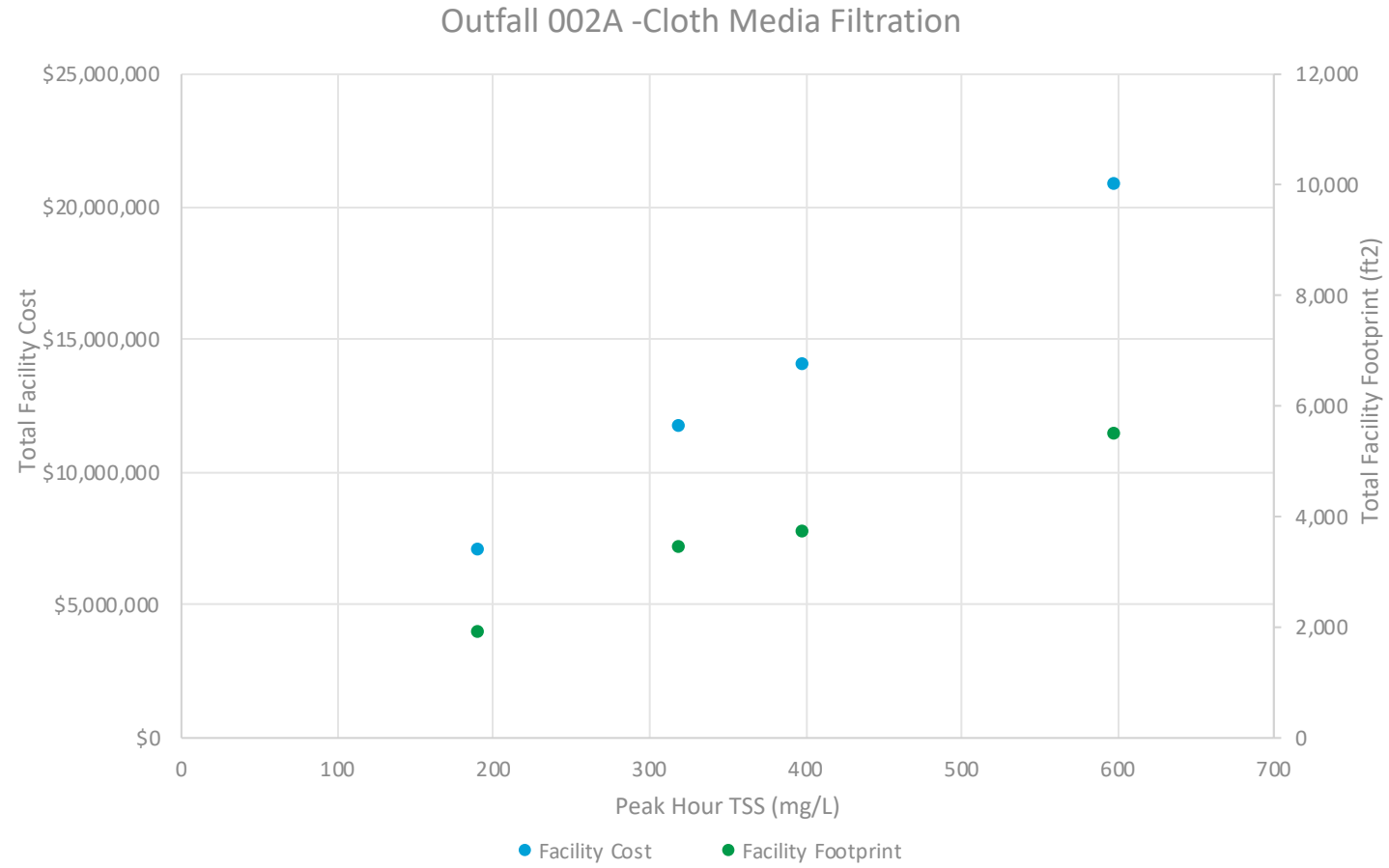

Outfall 002A

Compressible Media Filtration

- **WWETCO Filters**

- Durable synthetic balls which are compressed to create a porosity gradient resulting in the removal of large and small particles throughout the media bed
- Benefits to this type of implementation are the small footprint and relatively simple operation. While this technology is ideal for solids removal, any application for this analysis will require disinfection to meet permit limits.

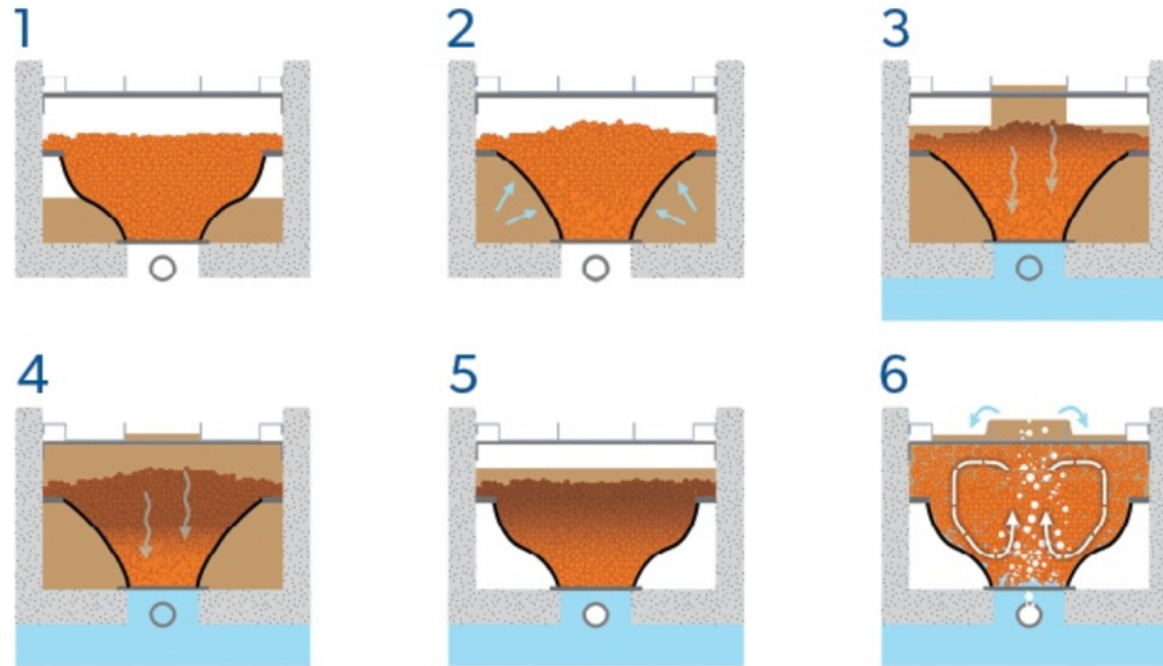

Outfall 002A

Compressible Media Filtration

- **WWETCO Filters**

- Costs and footprint can vary greatly based on the peak TSS concentration. This will need to be verified should this alternative be implemented.
- With an assumed peak TSS concentration of 320 mg/L, an approximate **footprint of 11,932 sf**

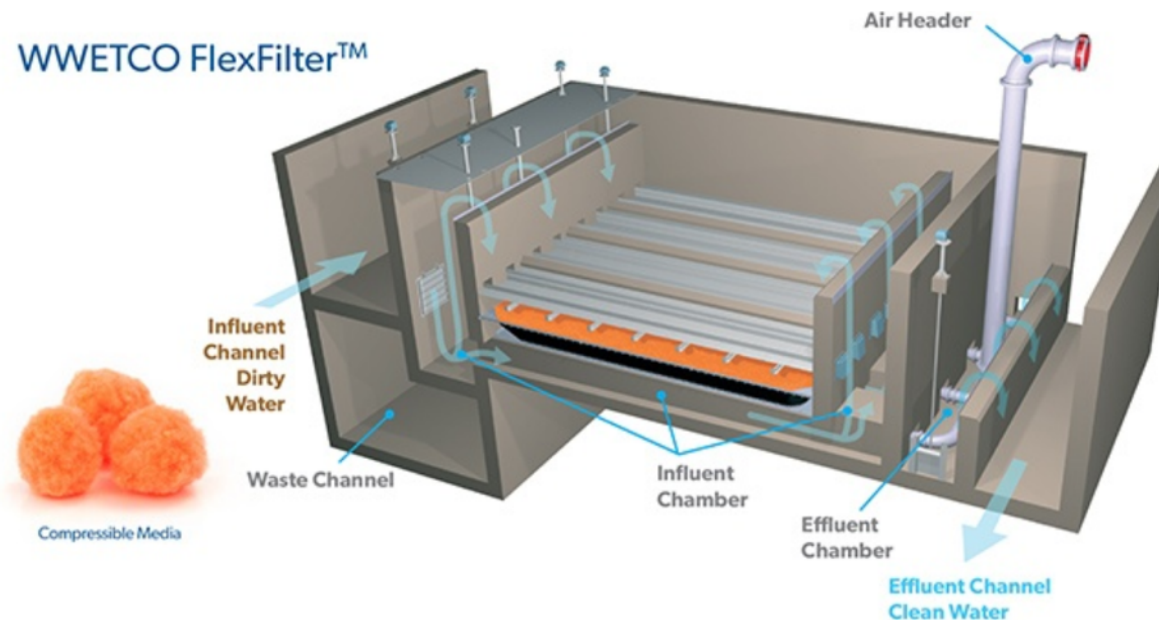

Outfall 005A (Central Hoboken)

Alternatives

- Disinfection:
 - Contact Basin in Water
- Storage:
 - CSO Storage Structure in the River
 - CSO Storage Structure at Stevens Park
 - CSO Storage Structure at Baseball Field
- Conveyance
 - Convey flows to plant through 5th Street pump station

Outfall 005A (Central Hoboken)

Overflow Volume

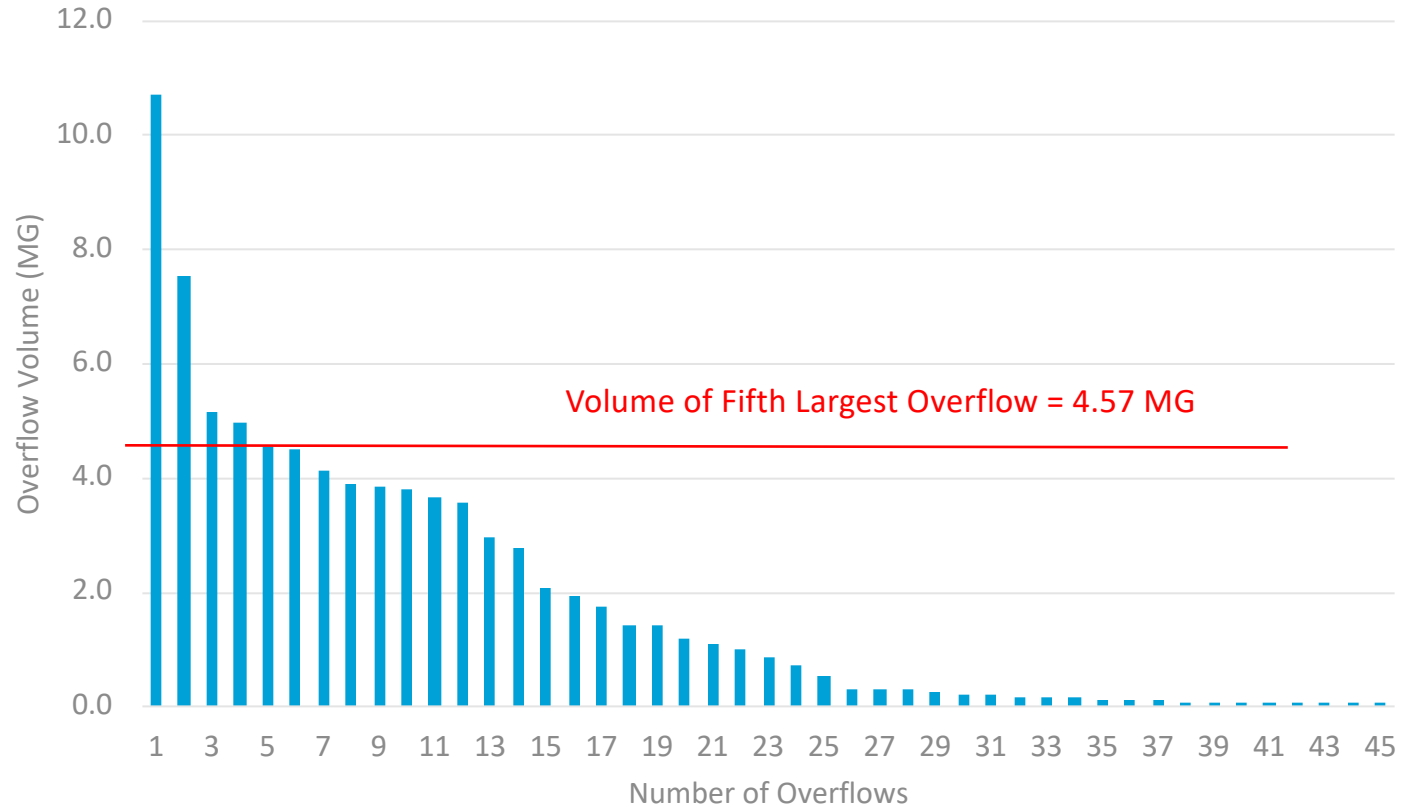

Outfall 005A

Treatment Facility in River

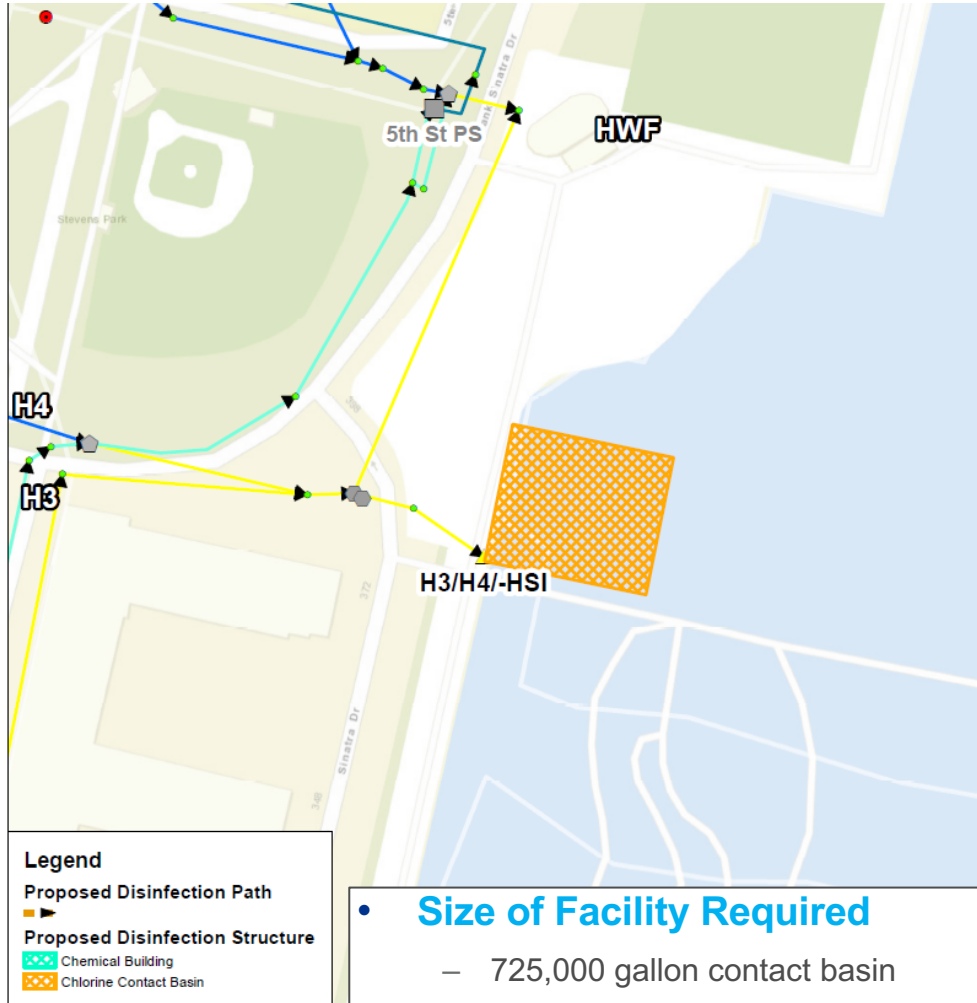

CSO Storage Structure In River

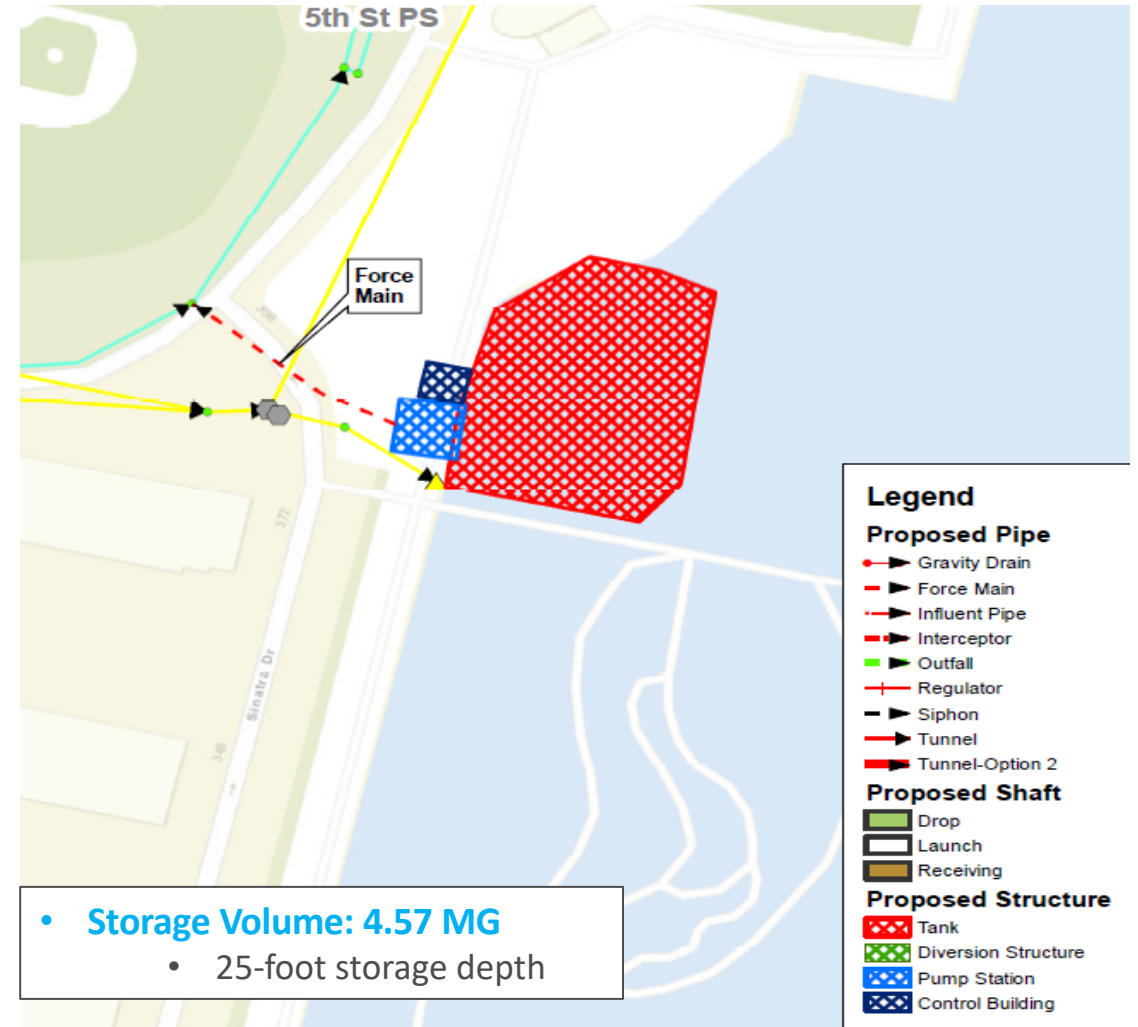

Outfall 005A

CSO Storage Structure at Stevens Park

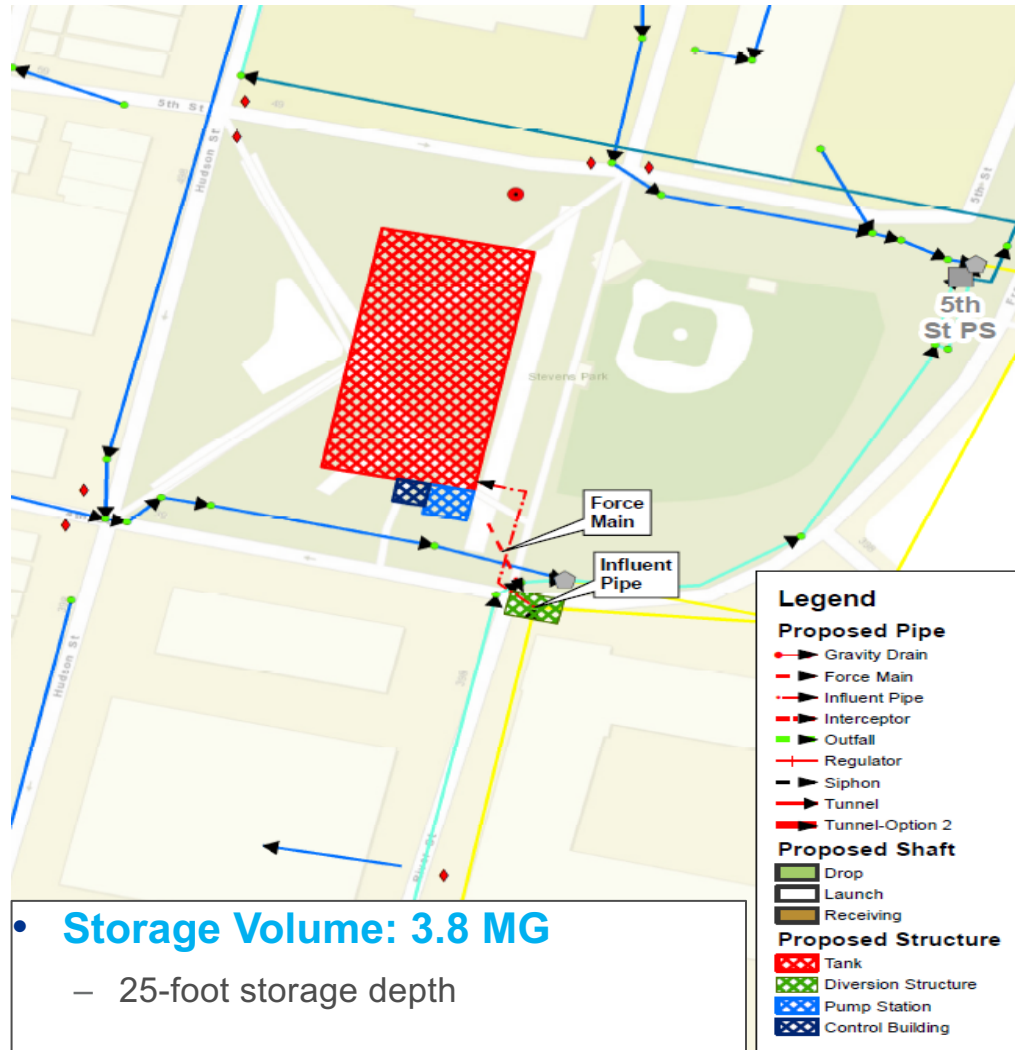

CSO Storage Structure at Baseball Field

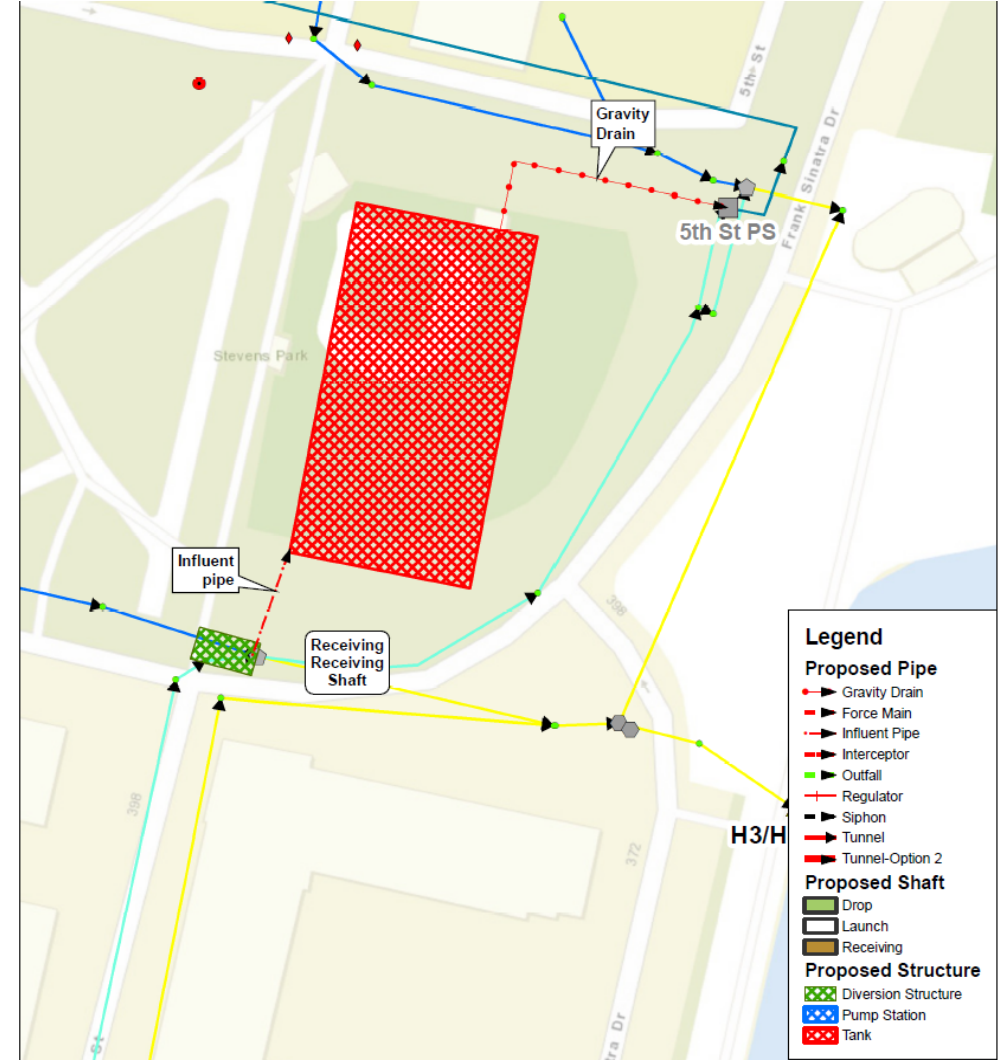

Outfall 005A

Convey Flows to Plant through 5th Street Pump Station

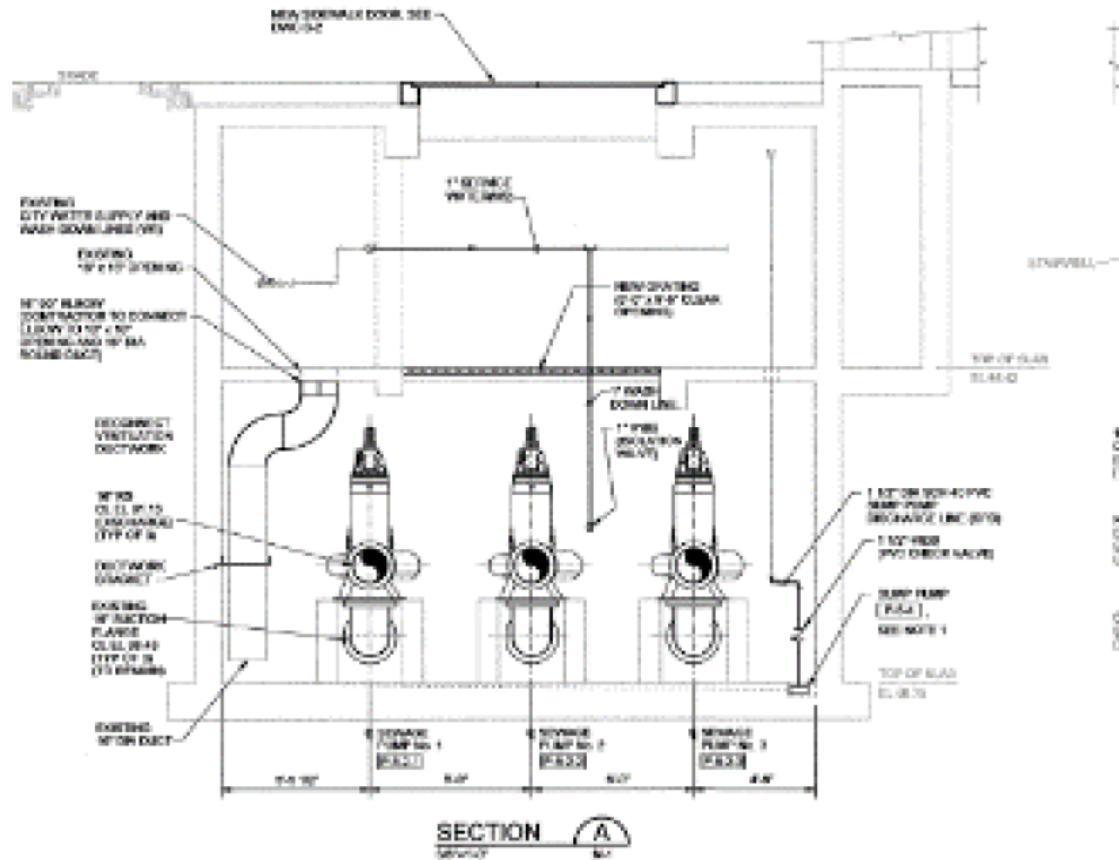

- **General**

- Adjust H3 and H4 regulator weirs
- Increased peak pumping rate to 31 MGD
- Upstream capacity will need to be monitored

Outfall 005A

Cloth Media Filtration vs Compressible Media Filtration

Cloth Media Filtration

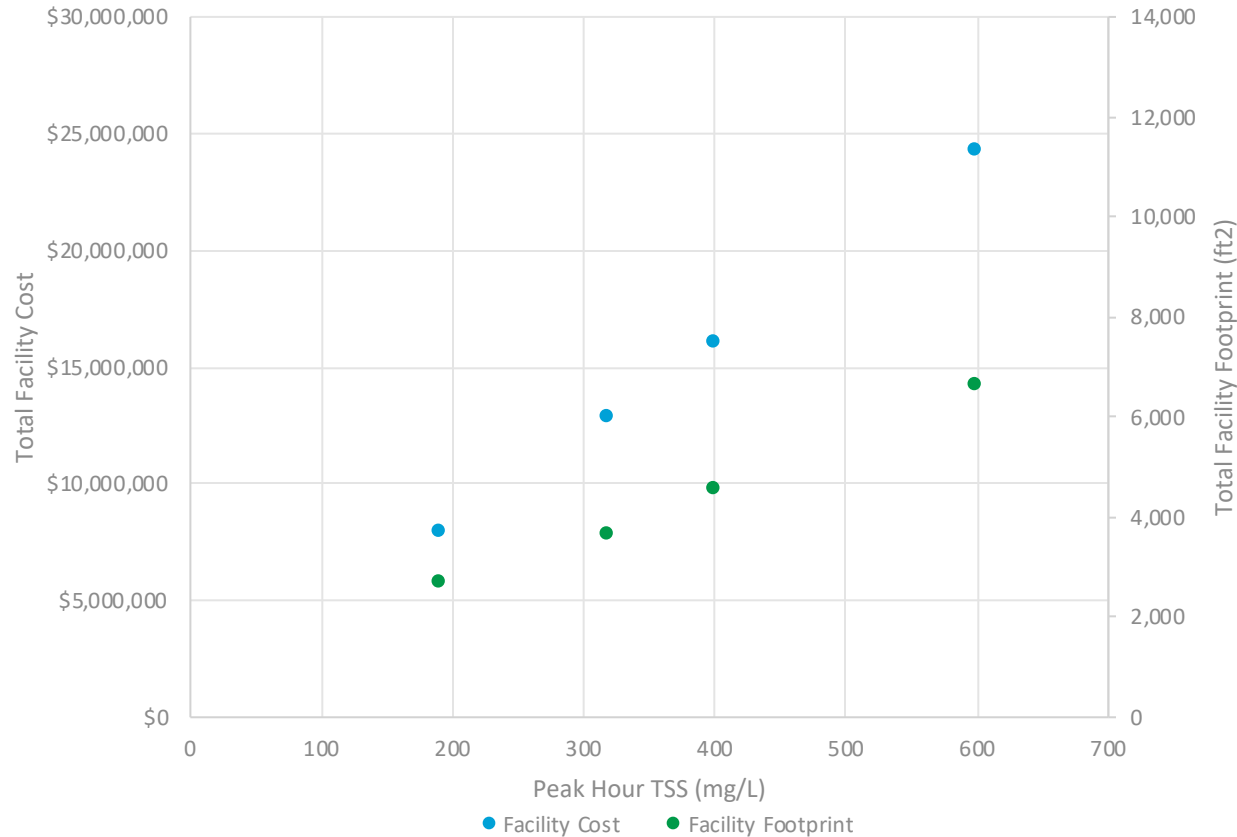

Compressible Media Filtration

- Costs and footprint can vary greatly based on the peak TSS concentration. This will need to be verified should this alternative be implemented
- With an assumed peak TSS concentration of 320 mg/L, an approximate **footprint of 14,318 sf**

H5 Basin (Northeast Hoboken)

Alternatives

- Disinfection:
 - Incorporate Disinfection with structure at Maxwell Plaza
- Storage:
 - Linear Storage to H3 Regulator and pump flows back to plant
 - CSO Storage at Maxwell Plaza
- Conveyance
 - Convey Flows to H3/H4/HSI Drainage Basin

Outfall 006A (Northeast Hoboken)

Overflow Volume

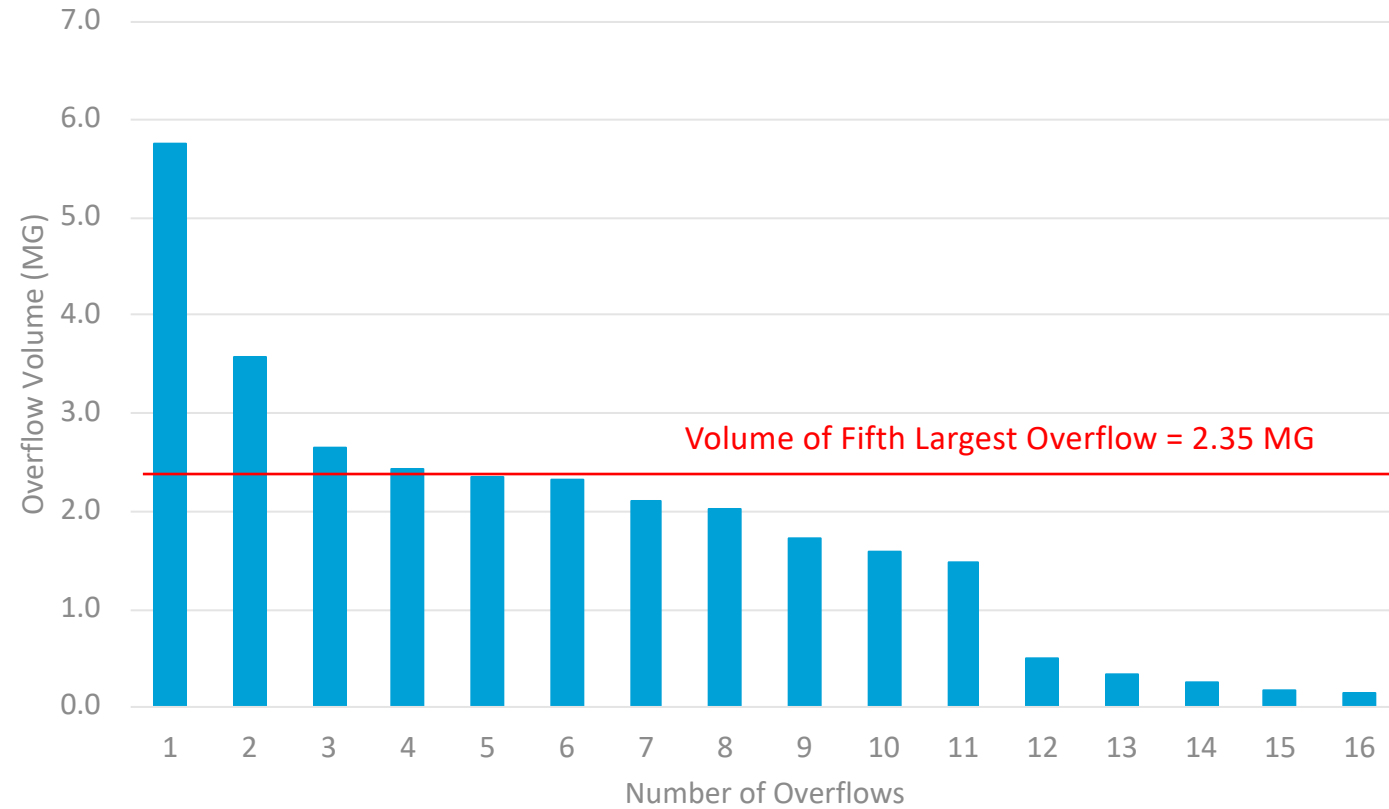

Outfall 006A

Contact Basin at Maxwell Place



CSO Storage Structure At Maxwell Place

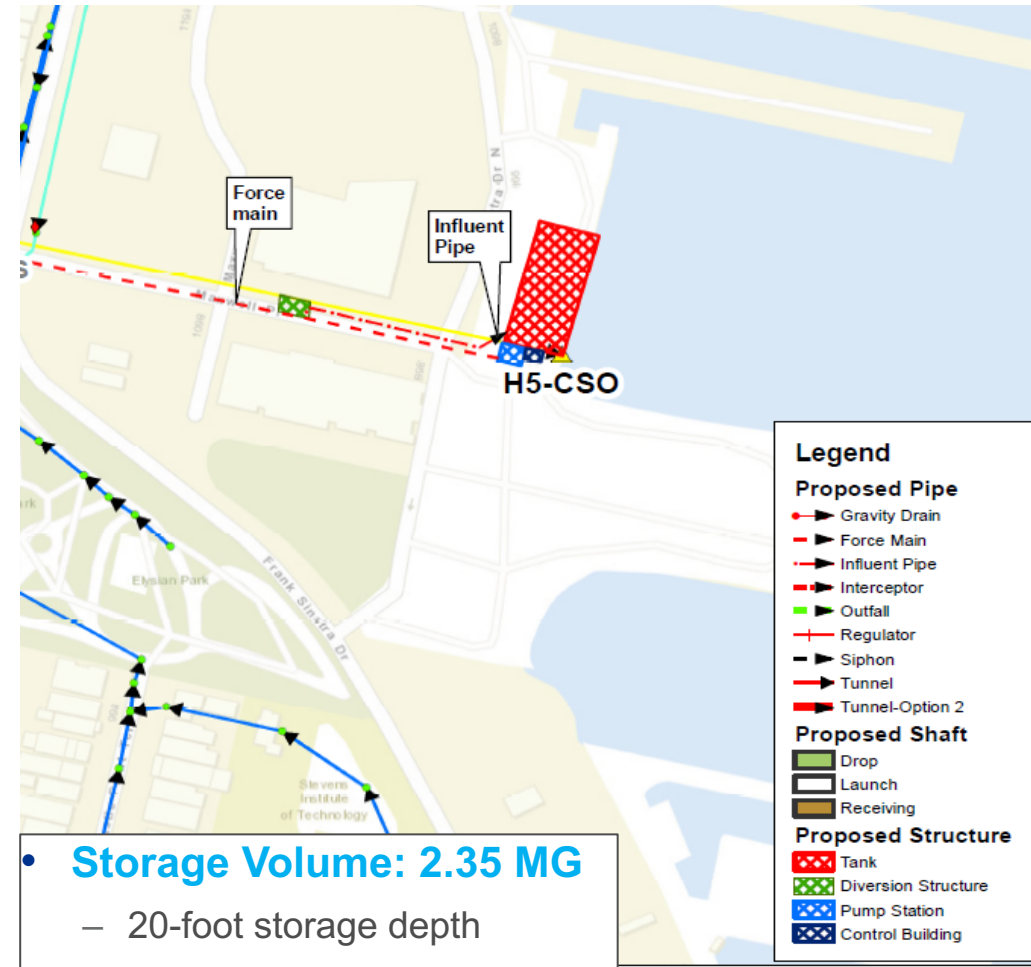

Outfall 006A

Convey Flows to H3/H4/HSI Outfall

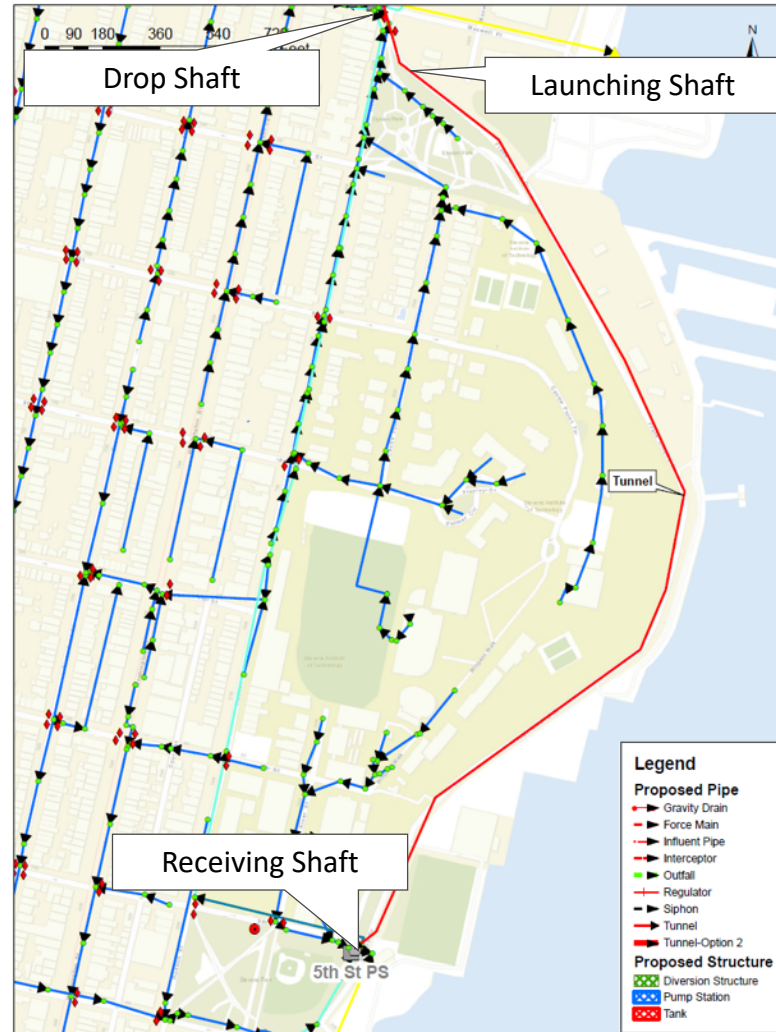

- **Tunnel Volume: 2.35 MG**
 - 3730' in length; 10' ID
- **Structure**
 - 20 feet of cover

Outfall 006A

Modify the H5 Regulator to convey additional flow to the 11th St Pump Station

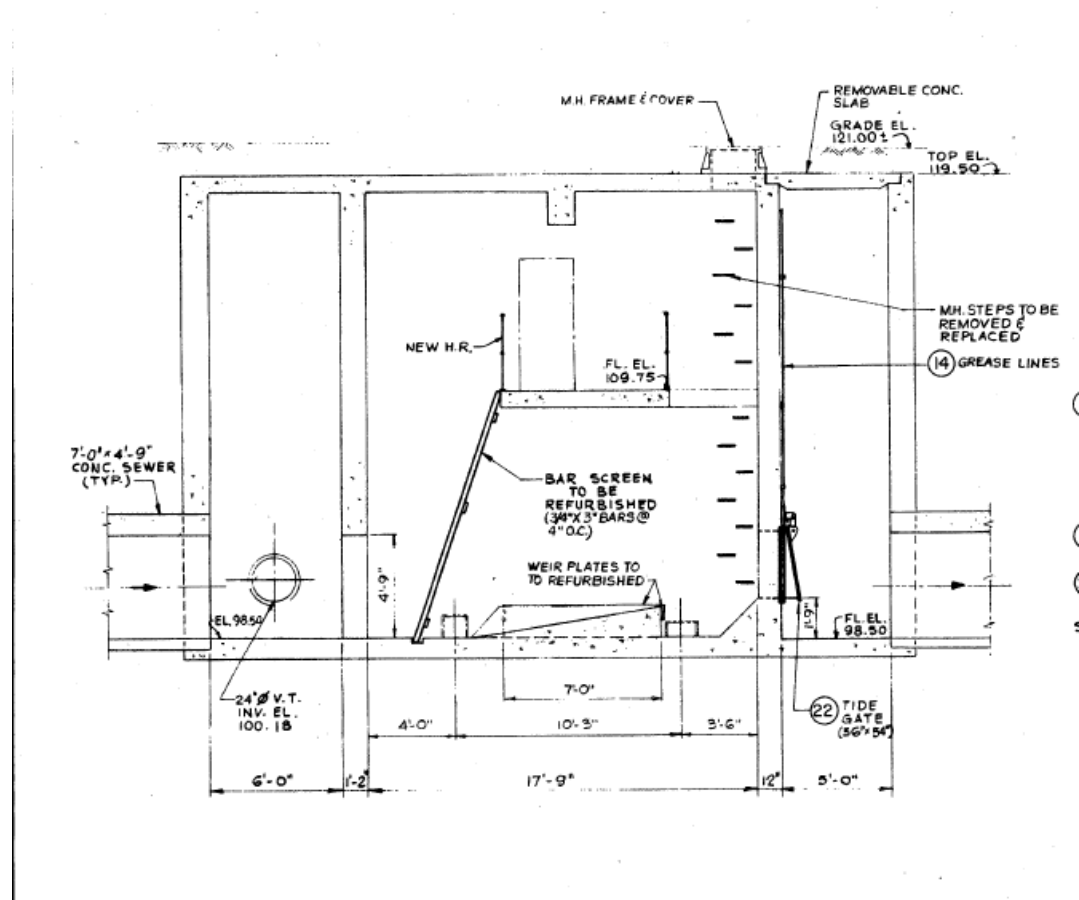

- General

- Adjust H5 Regulator Weir
- Increase pump station capacity from 10 to 31 MGD

Outfall 006A

Cloth Media Filtration vs Compressible Media Filtration

Cloth Media Filtration

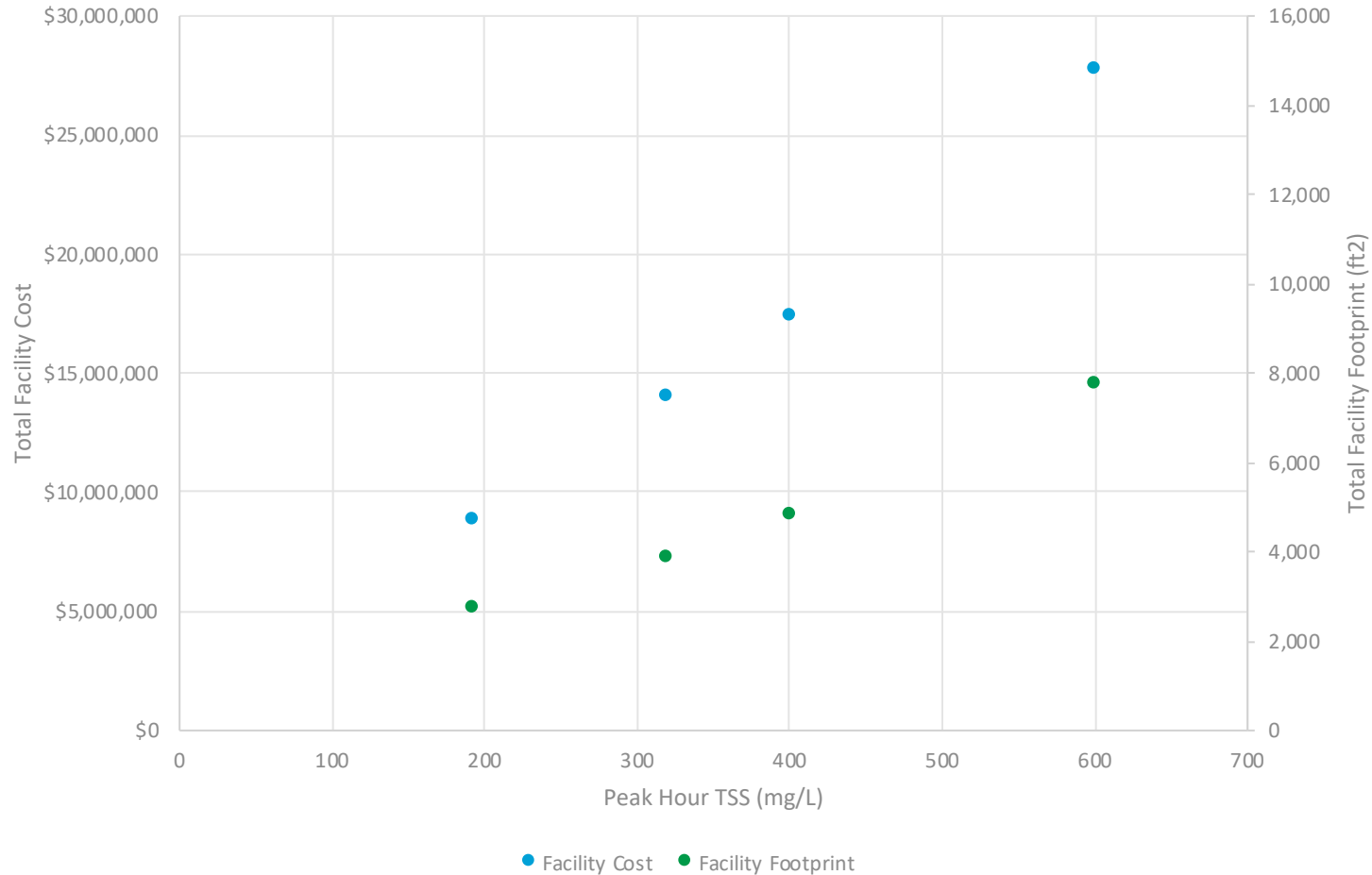

Compressible Media Filtration

- Costs and footprint can vary greatly based on the peak TSS concentration. This will need to be verified should this alternative be implemented
- With an assumed peak TSS concentration of 320 mg/L, an approximate **footprint of 14,646 sf**

Outfall 008A (North Hoboken)

Overflow Volume

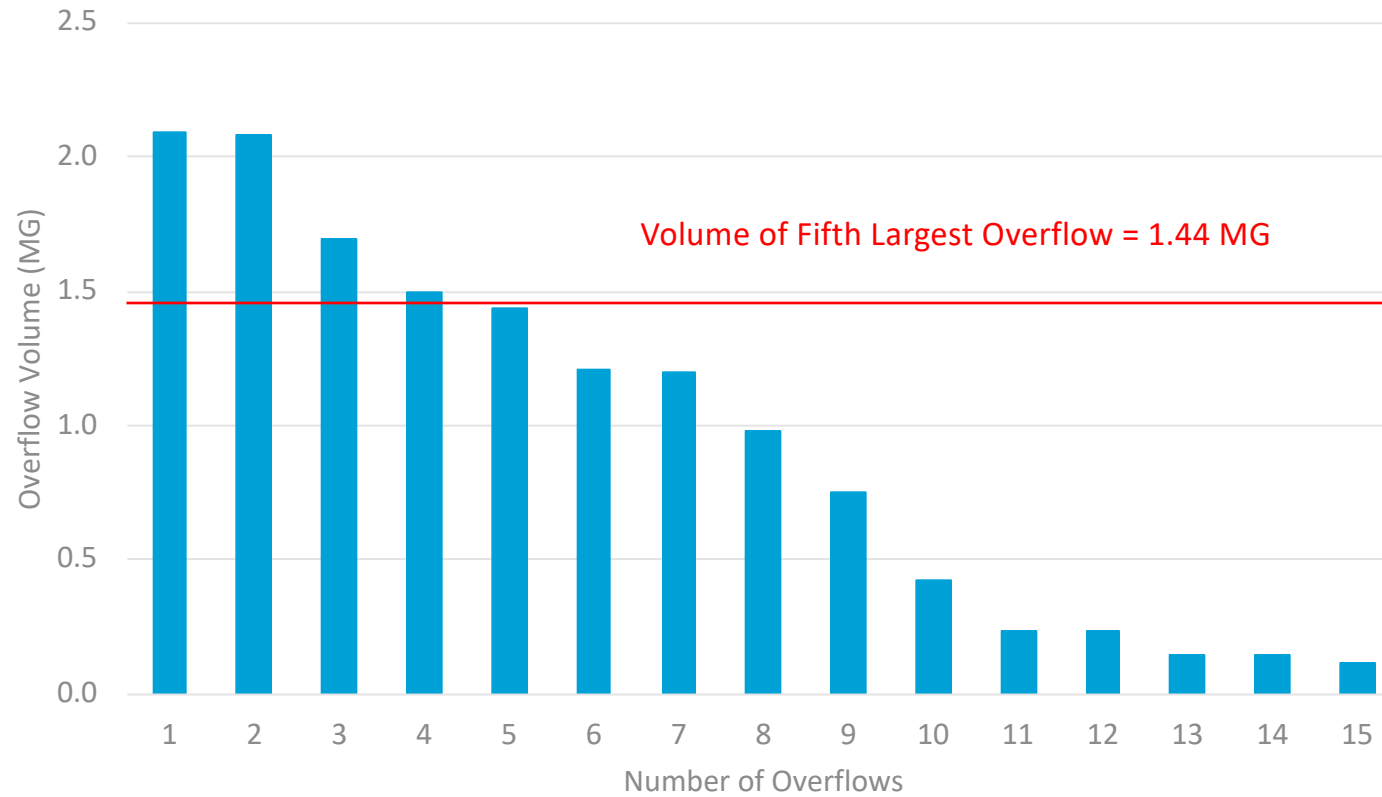

Outfall 008A (North Hoboken)

High Level Storm Sewer and Underground Storage

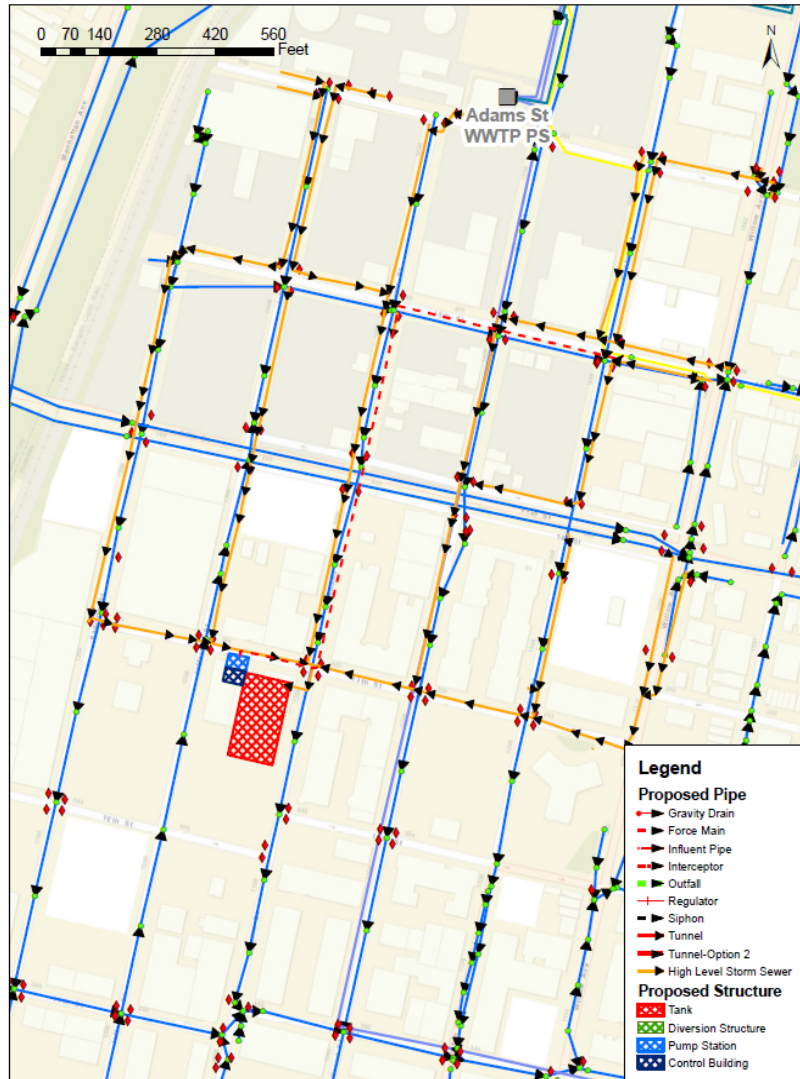

- **Structure**

- Parallel system to existing system throughout roadway
- Utilize existing inlets
- 1 MG storage tank beneath New Northwest Resiliency park



Outfall 013A (Weehawken)

Alternatives

- Disinfection:
 - Disinfect at W1234 S/F Facility
- Storage/Conveyance:
 - Install a 3rd barrel for the Park Avenue Siphon
 - Relocate Regulators W1, W2, and W3
 - Separate the W4 basin with above ground storage

Outfall 013A (Weehawken)

Overflow Volume

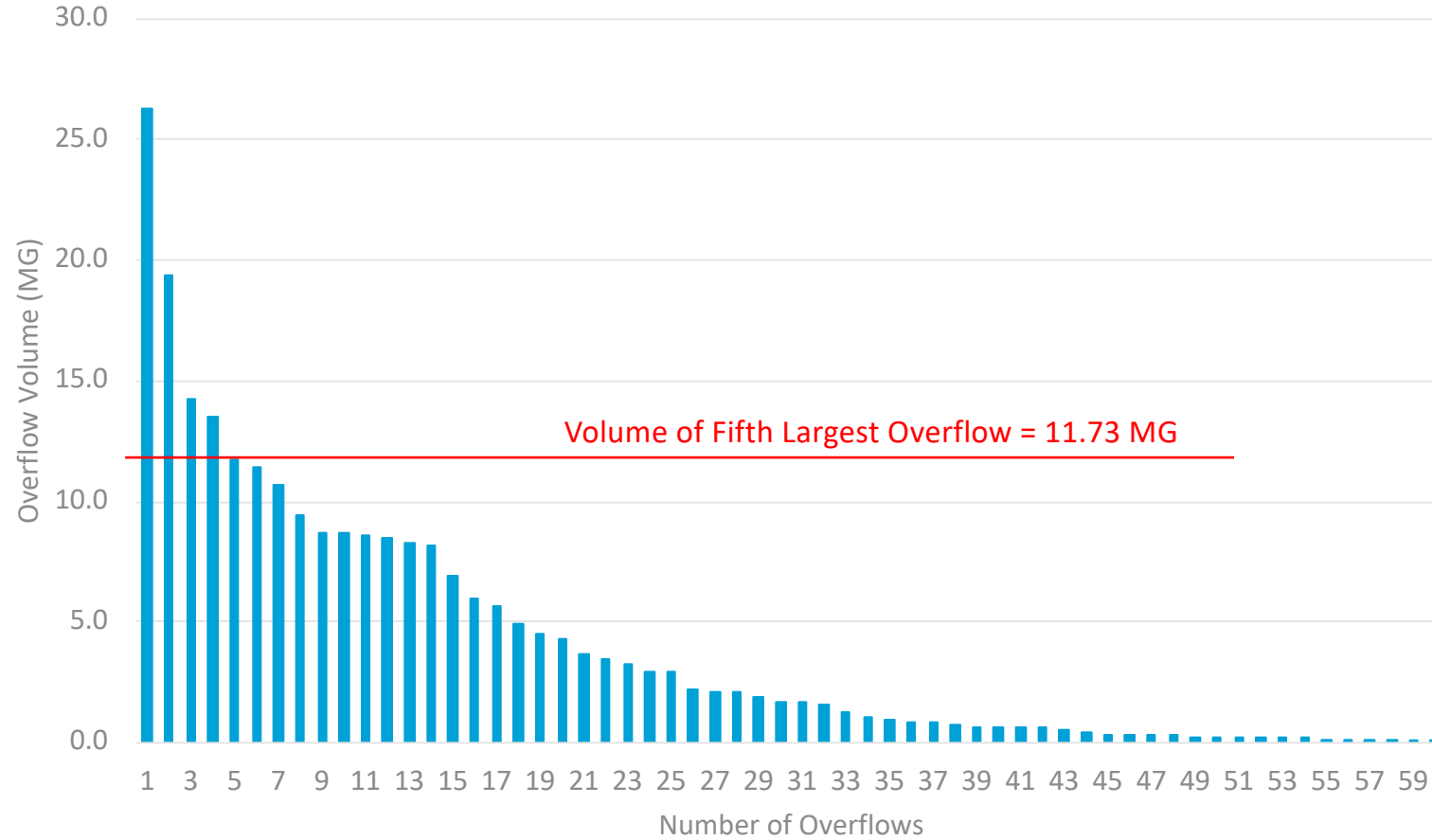

Outfall 013A

Disinfect at W1234 S/F Facility

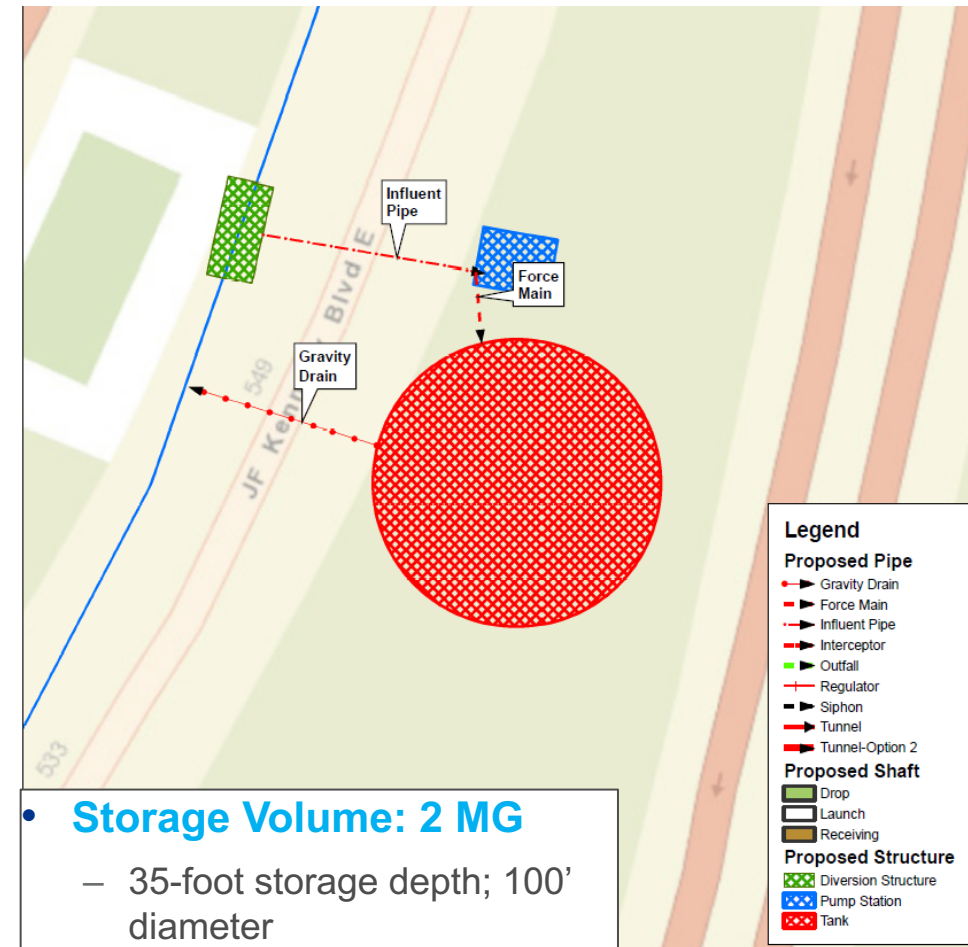
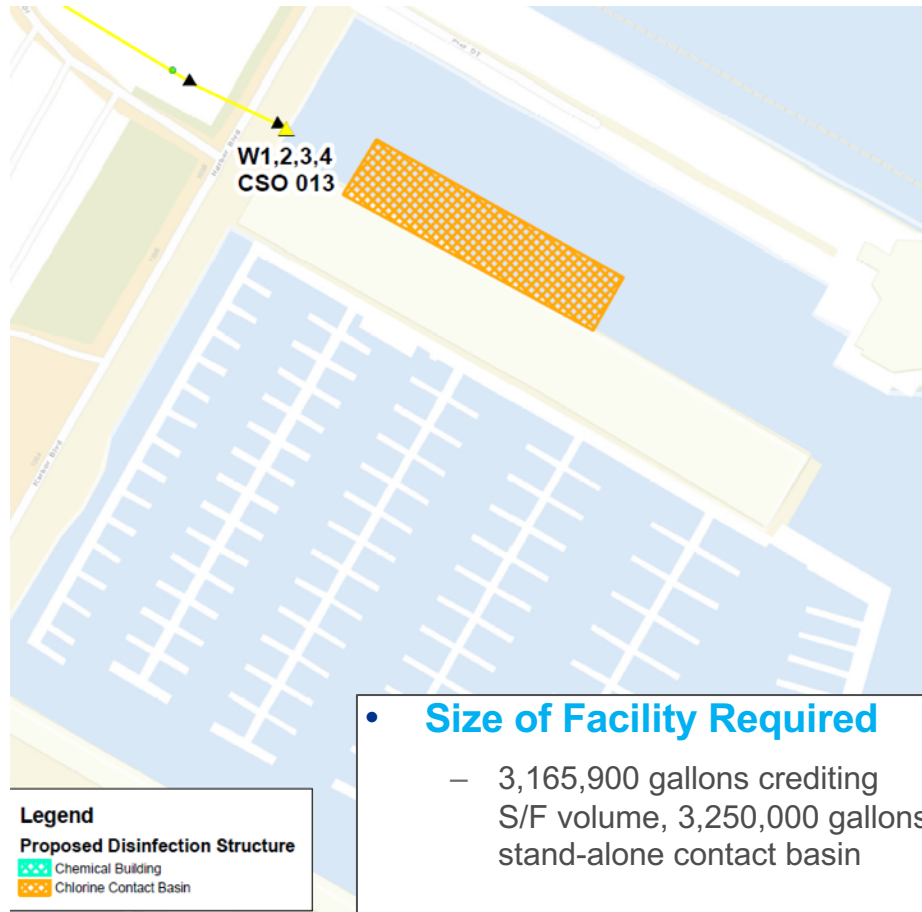

Outfall 013A

Install a 3rd barrel for the Park Avenue Siphon



- **Structure**
 - Parallel to existing Siphon
- **Piping**
 - 48” Pipe; next increment size from existing 24” and 12”

Outfall 013A

Relocate Regulators W1, W2, and W3

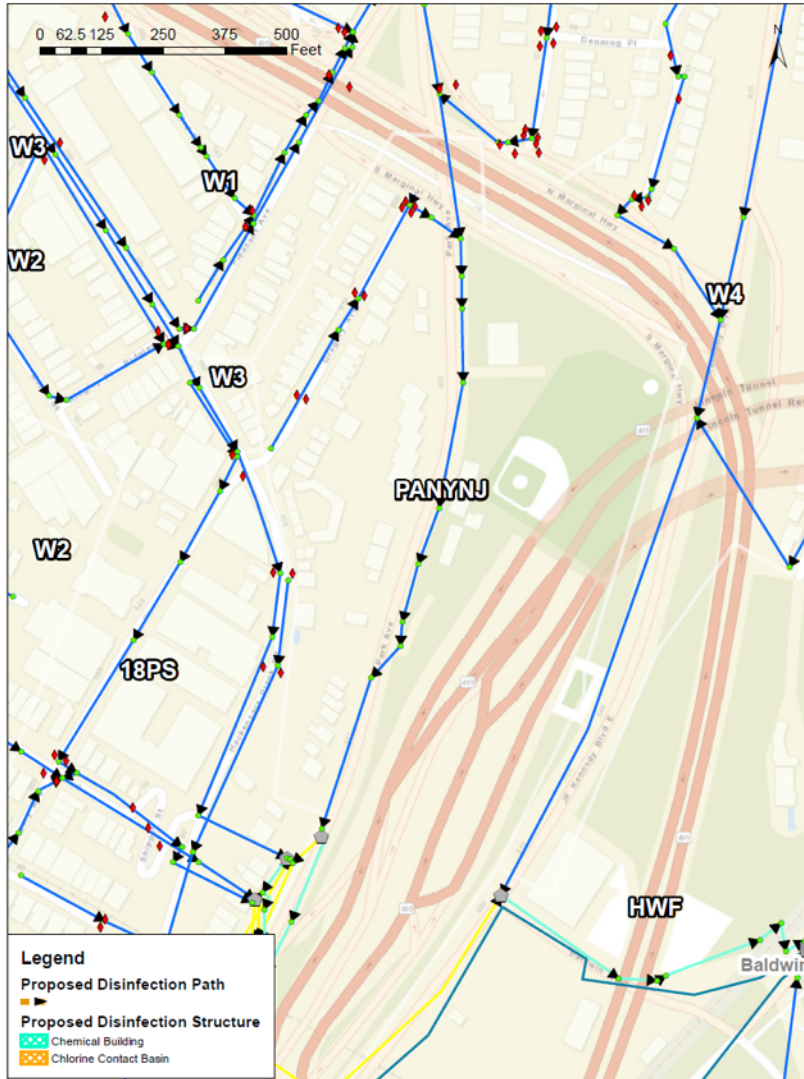

- Potential Construction

- With potential work on proposed tunnel and increasing siphon capacity, this would provide an opportunity to relocate regulators to aid in decelerating flow to interceptor
- This alternative is not expected to reduce flows significantly and will be combined with the other proposed alternatives for W1234 which convey flow to the plant for optimization

Outfall 013A

Cloth Media Filtration vs Compressible Media Filtration

Cloth Media Filtration

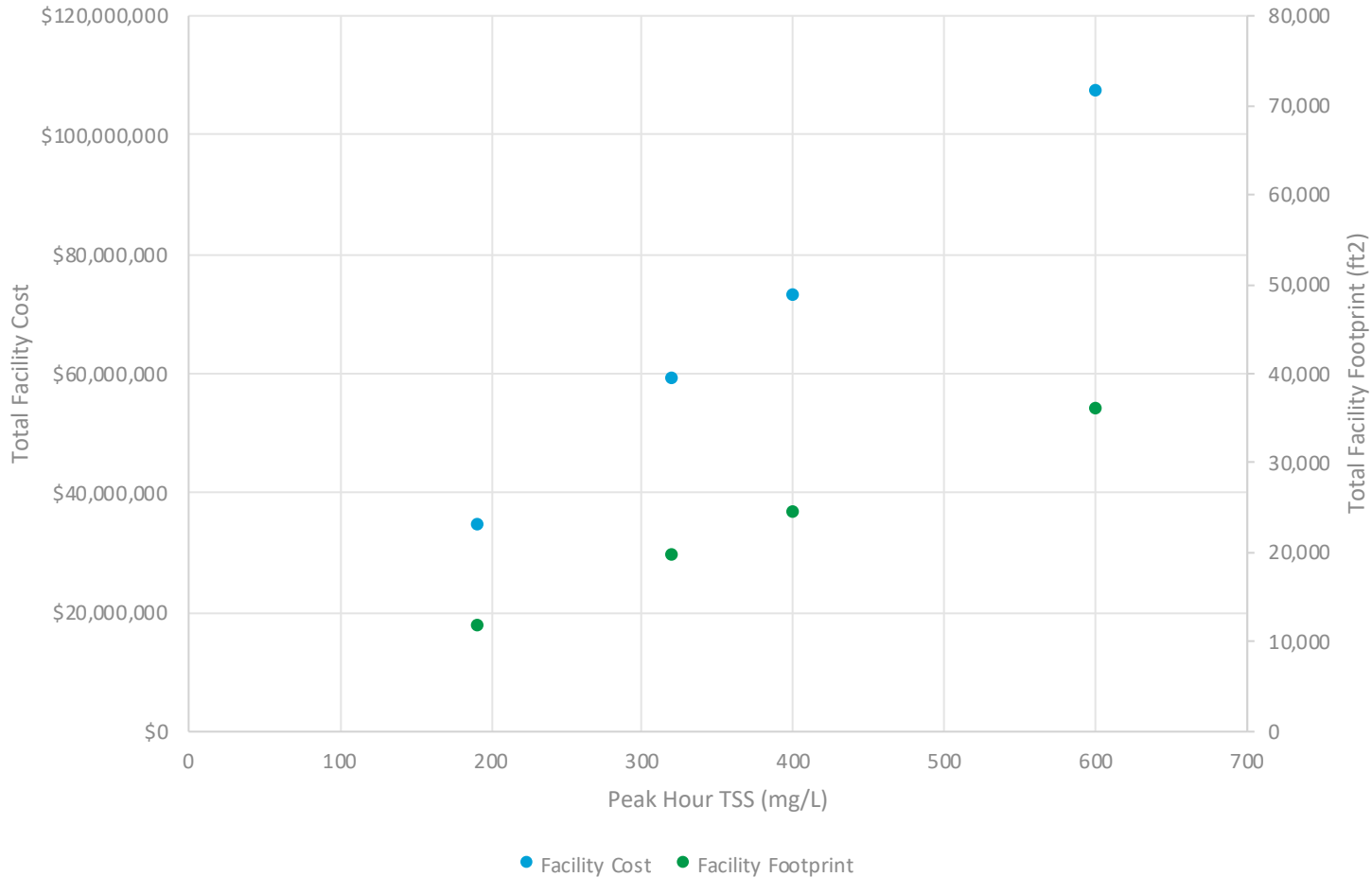

Compressible Media Filtration

- Costs and footprint can vary greatly based on the peak TSS concentration. This will need to be verified should this alternative be implemented
- With an assumed peak TSS concentration of 320 mg/L, an approximate **footprint of 59,659 sf**

Outfall 012A (South Weehawken)

Alternatives

- Conveyance:
 - Increase Capacity of 18th Street Pump Station

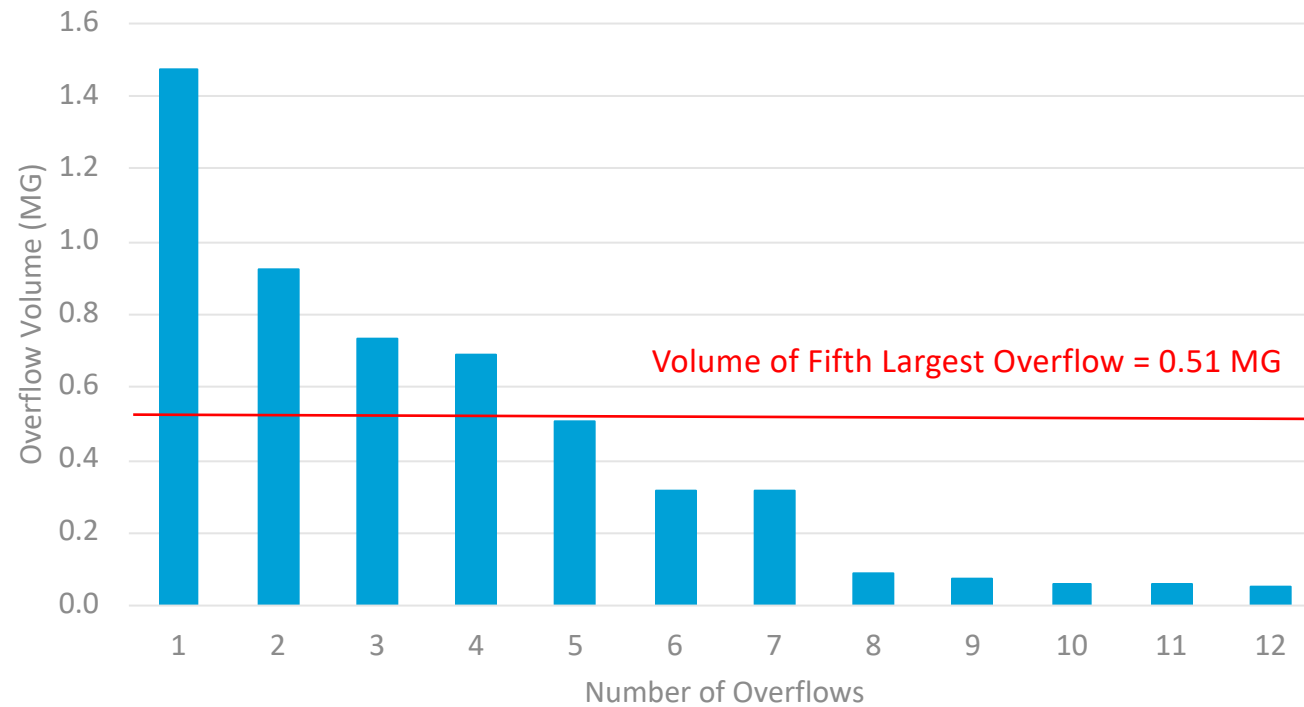

Outfall 012A

Increase Capacity of 18th Street Pumping Station

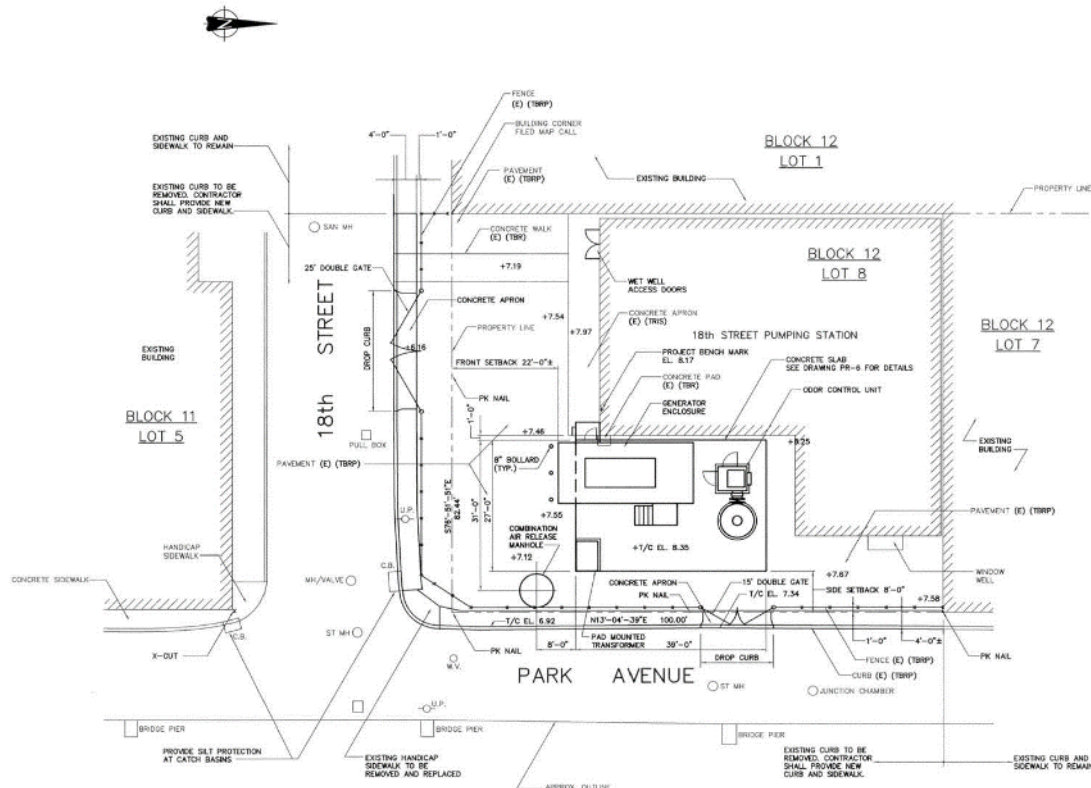

- General
 - Upgraded Capacity to 18 MGD

Outfall 015A (North Weehawken)

Alternatives

- Conveyance

- Separate Storm Sewer System

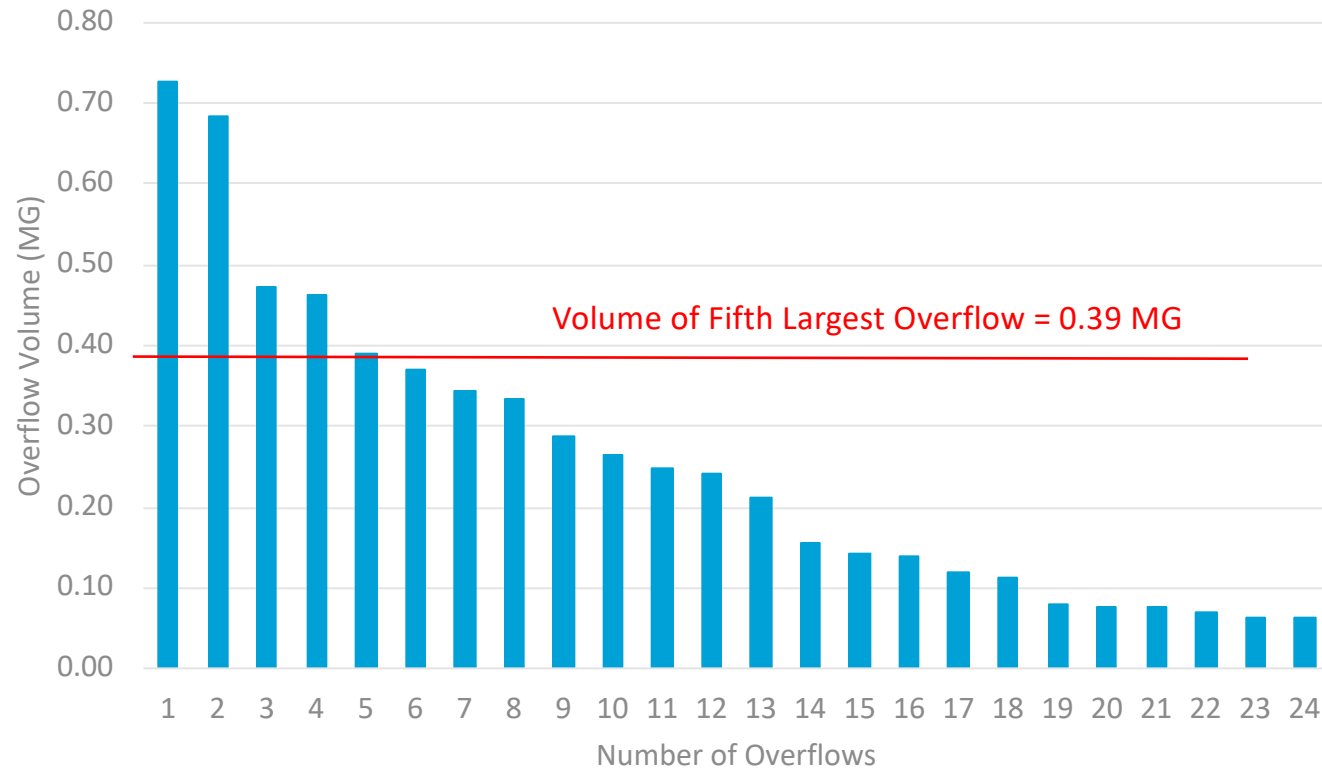

Outfall 015A

High Level Storm Sewer

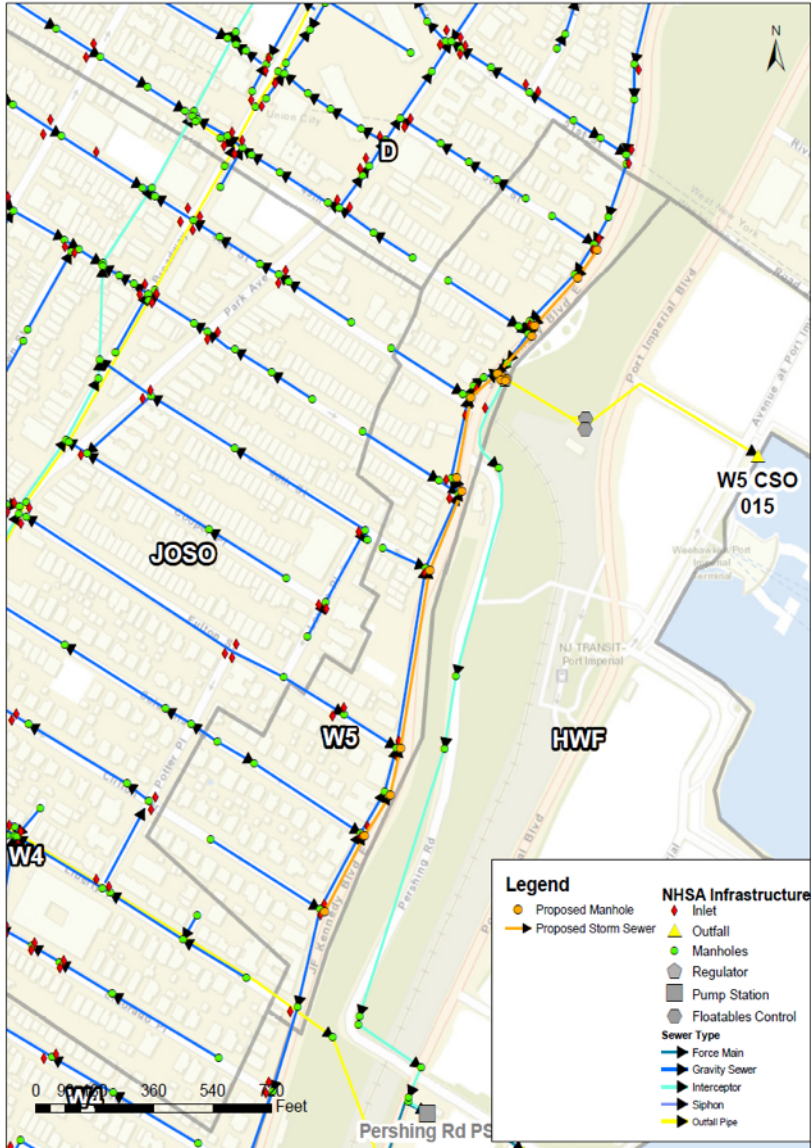

- **Structure**

- Parallel system to existing system along John F Kennedy Blvd
- Utilize existing inlets
- Reconfigure regulator to direct sanitary flows to existing 12" Interceptor

Adams Street Service Area

Green Infrastructure

- Based on a land use analysis in the preliminary screening phase, it was estimated that an average of 20% of the total impervious area could be managed by green infrastructure within the Adams Street service area.
- A bioretention calculation was completed to estimate the total amount of capture within the subcatchments and the area of green infrastructure that would be required.

Adams Street Service Area

Inflow/Infiltration

- Based on the EPA condition assessment of estimating infiltration (June 2014), the total inch diameter-miles of pipe is calculated for each drainage basin
- This unit of length is divided by the baseflow extracted from the model (mgd) and converted to a rate to represent the approximate infiltration per inch diameter-mile, or gpd/idm, of groundwater infiltration.
- In the Adams Street Service area, RedZone data was collected for the W1, W2, W3, W4, W5 and 18PS metersheds. It was assumed that pipes with a PACP score of at least 3 contributed to this infiltration

Adams Street WWTP Capacity Improvements

- Equalization of Peak Flow
 - Install Storage Tank at Trickling Filter
- Treatment
 - Blending to Allow for Increased Capacity at the WWTP
 1. Split peak flows around the filter portion of the PURAC system during wet weather to increase peak secondary capacity from 32 mgd to 40 mgd
 2. Provide up to 52 mgd total WWTP capacity by blending 20 mgd of disinfected primary effluent from Primary Clarifier No. 1 with 32 mgd receiving primary treatment in Primary Clarifiers Nos. 2 & 3, secondary treatment, and UV disinfection
- Conveyance
 - New Plant Outfall at Adams Street WWTP

Adams Street WWTP

Install Storage Tank at Tricking Filter

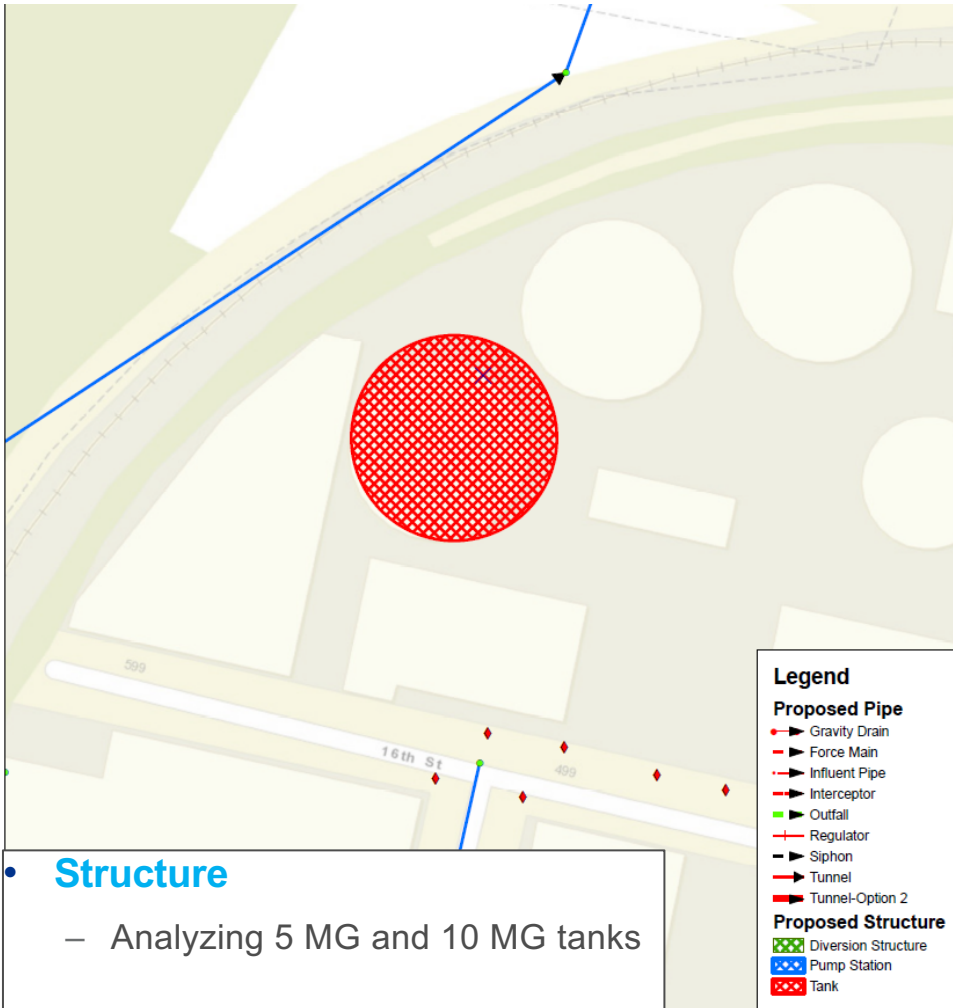

Construct New Plant Outfall

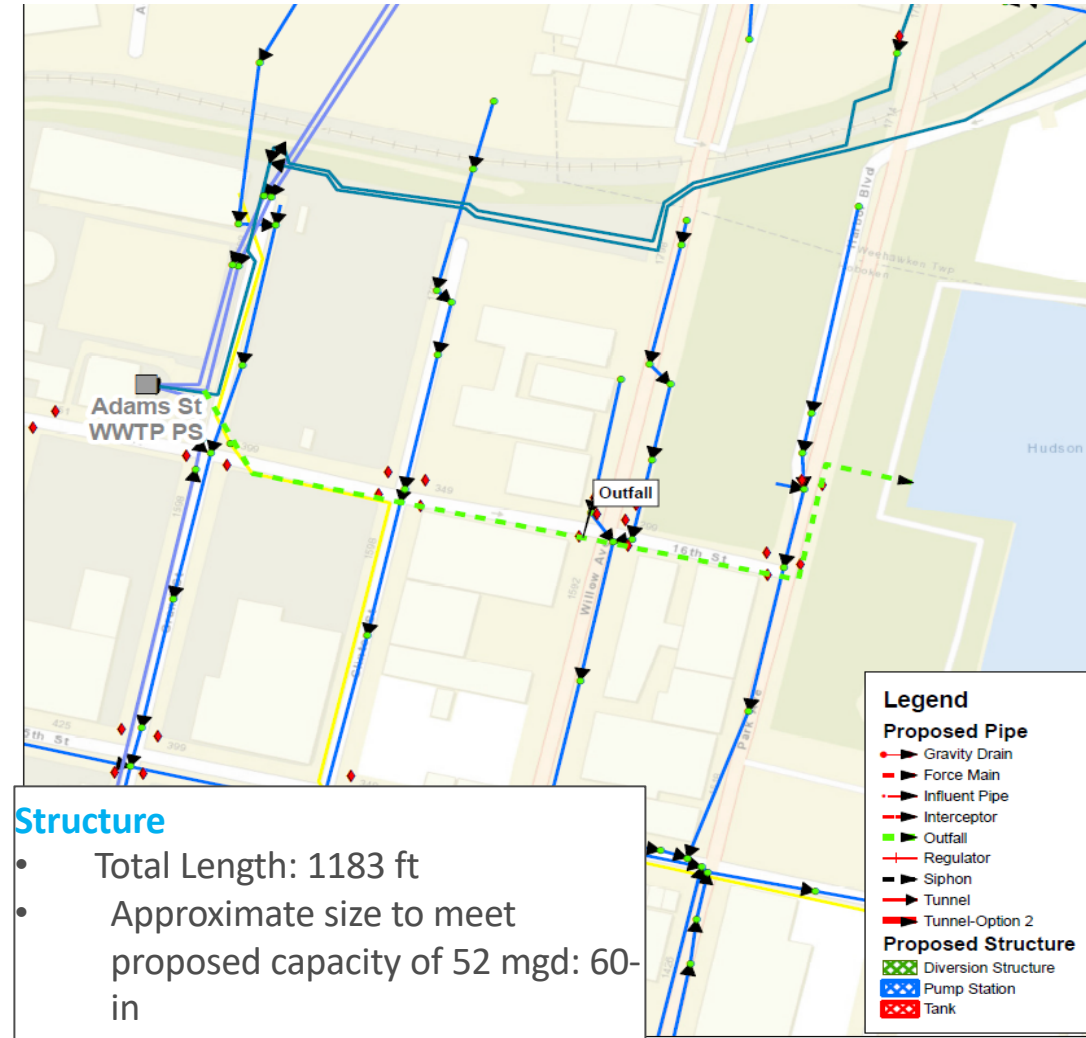

Adams Street WWTP

Blending Disinfected Primary Effluent with Secondary UV Disinfected Effluent to Allow for Increased Capacity at the WWTP Proposed Process Flow Diagram

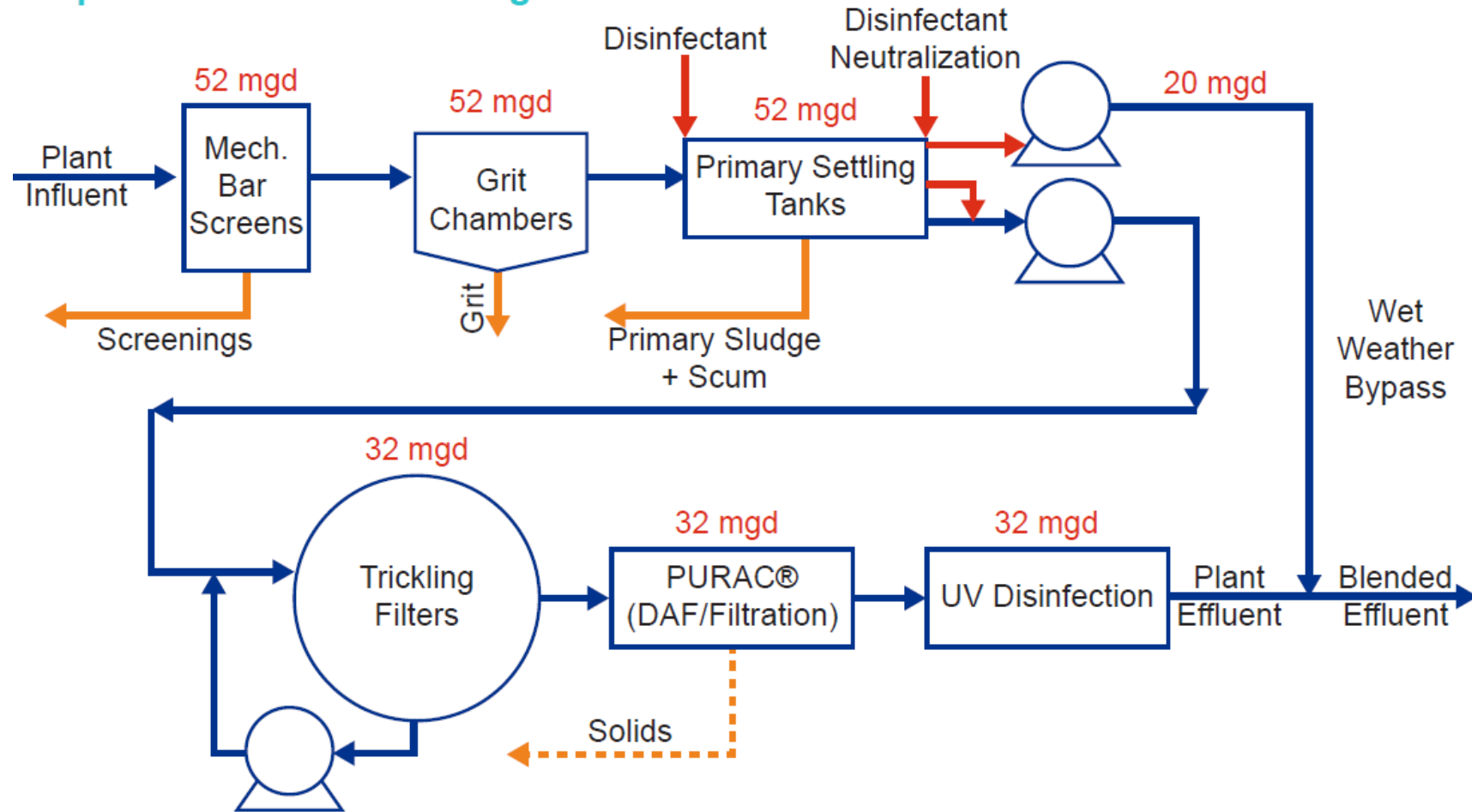

Alternatives Evaluations - River Road



River Road Combined Sewer System Performance for a Typical Year

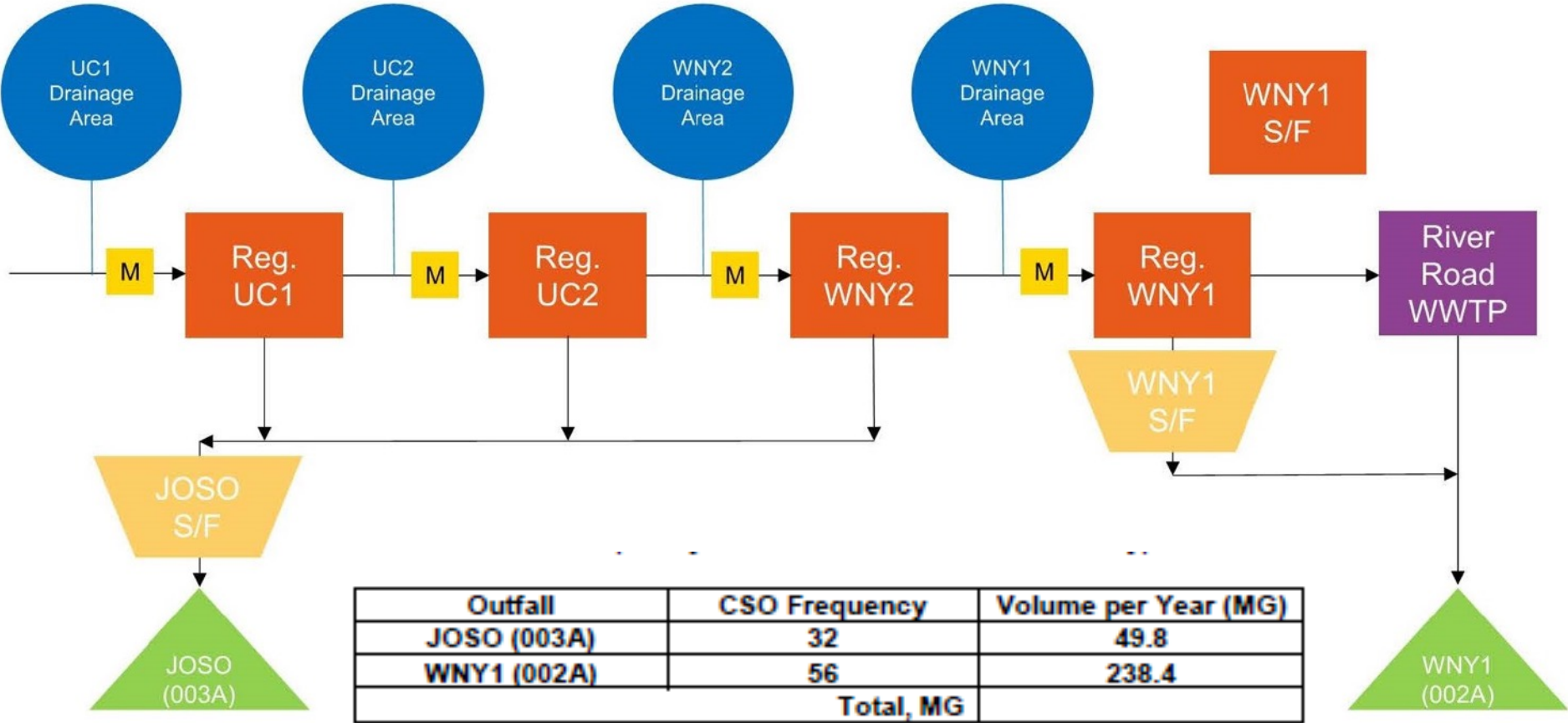

Outfall 003A (Weehawken)

Alternatives

- Conveyance:
 - Raise Regulator Weirs at UC1, UC2 and/or WNY2
 - Replace existing JOSO side-flow weirs with bending weirs
- Storage
 - CSO Storage Structure constructed in River

Outfall 003A (Weehawken)

Overflow Volume

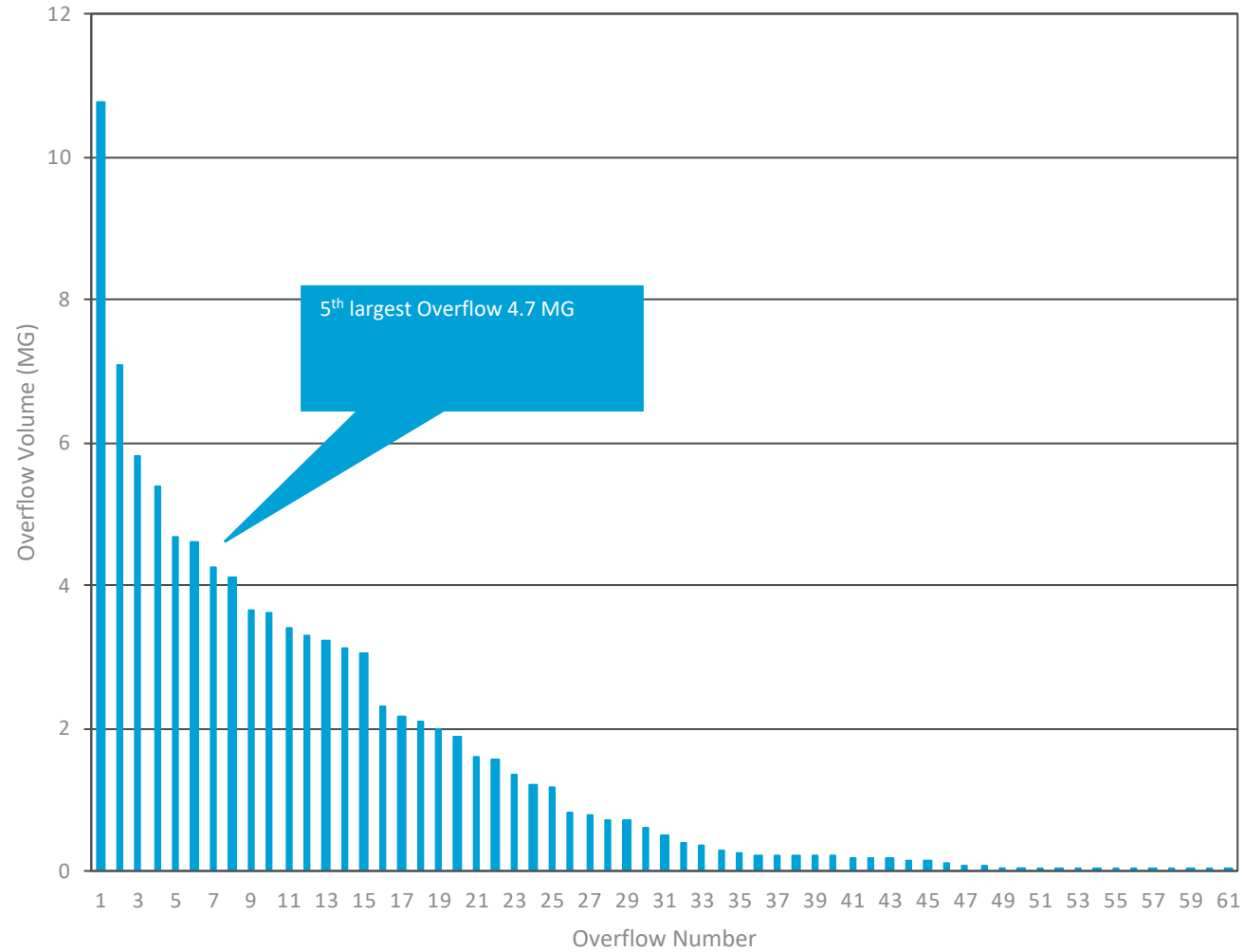

Outfall 003A

Raise Regulator Weirs at UC1, UC2 and/or WNY2



- General
 - Divert flows to WWTP and minimize amount routed to JOSO outfall
 - Iterate scenarios raising weirs and analyzing overflow amounts
- Next modeling phase
 - Model alternative with free outfall at River Road WWTP and analyze flows and volumes at plant to determine plant capacity required for alternative

Outfall 003A

Replace existing JOSO side-flow weirs with bending weirs

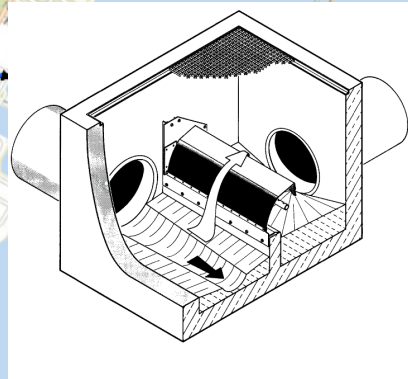

- Bending weir not available for WNY1
- Generates 0.08 MGD of storage along interceptor

	Number of Overflows		Total CSO Volume (Mgal)	
	Existing	Bending Weirs	Existing	Bending Weirs
JOSO (003A)	61	24	95	28
River Road (002A)	60	60	190	254

Outfall 003A

CSO Storage Structure constructed in River



- **Storage Volume: 4.7 MG**
 - 10-foot storage depth; 250'L x 250'W

Outfall 001A/002A (West New York)

Alternatives

- Storage:
 - Linear Storage along Anthony Defino Way
 - CSO Storage Structure Constructed in River

Outfall 001A/002A (West New York)

Overflow Volume

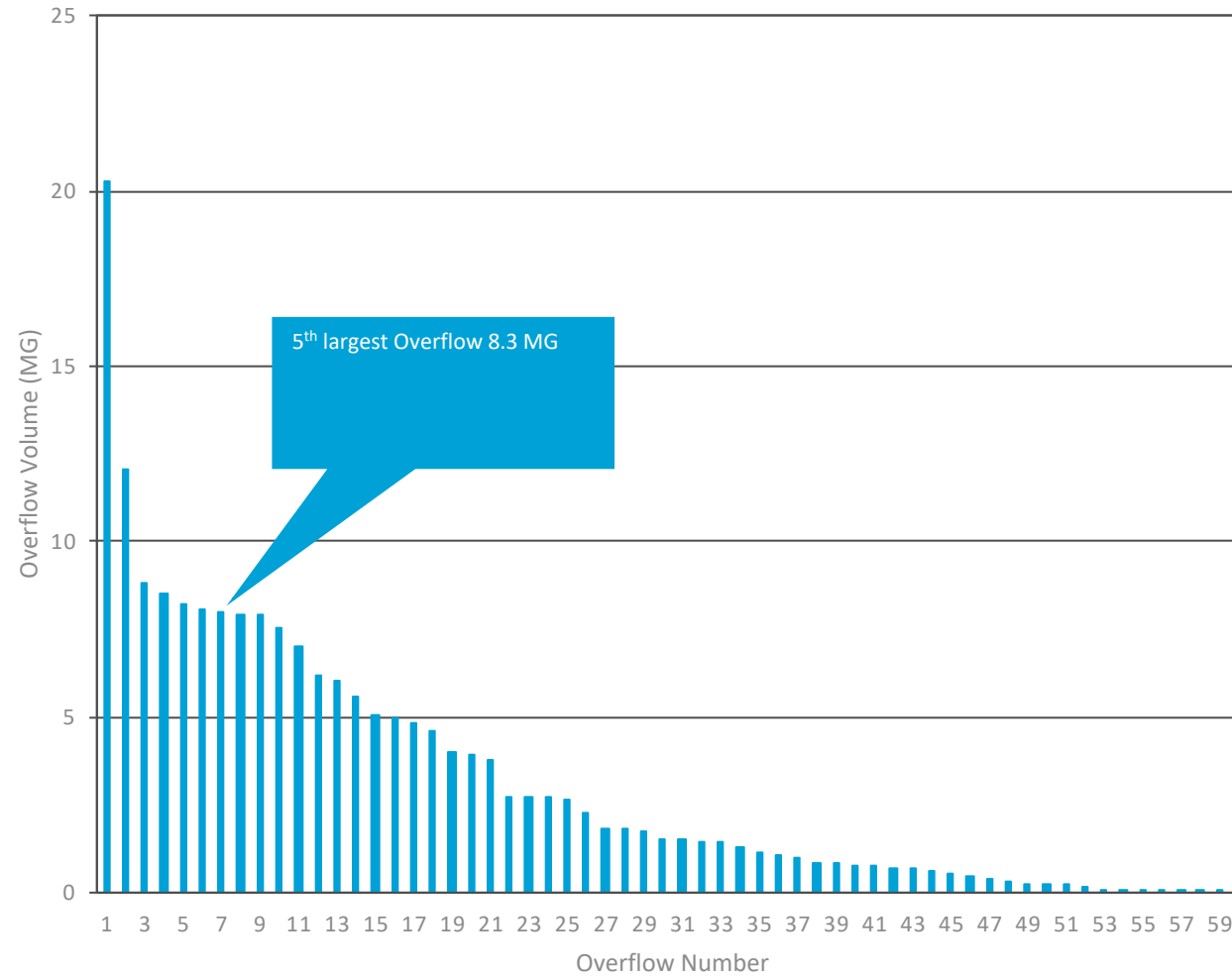

Outfall 001A/002A

Linear Storage along Anthony M. Defino Way

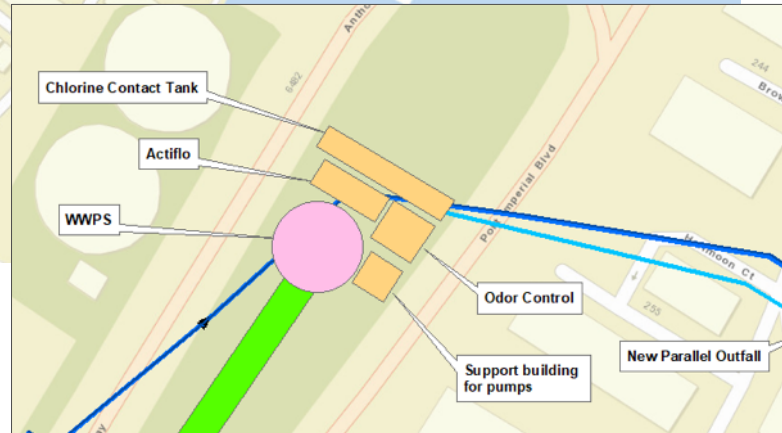

- 2,200 ft long, 26 ft diameter = 8.3 MG storage
- Number of overflow events at River Road reduced from 60 to zero. No improvement at JOSO but can combine with weir optimization
- Site considerations: slope, existing infrastructure
- Vortex drop structure, WWPS, HRT, disinfection, new parallel outfall, tide gate

Outfall 001A/002A

CSO Storage Structure Constructed in River



- **Storage Volume: 8.3 MG**
 - 30-foot storage depth; 220'L x 170'W

Inflow/Infiltration

- Based on the EPA condition assessment of estimating infiltration (June 2014), the total inch diameter-miles of pipe is calculated for each drainage basin
- This unit of length is divided by the baseflow extracted from the model (mgd) and converted to a rate to represent the approximate infiltration per inch diameter-mile, or gpd/idm, of groundwater infiltration.
- In the River Road Service area, RedZone data was collected for the UC1, UC2, WNY2 and WNY1 metersheds. It was assumed that pipes with a PACP score of at least 3 contributed to this infiltration

System Wide

Green Infrastructure

- Based on a land use analysis in the preliminary screening phase, it was estimated that an average of 20% of the total impervious area could be managed by green infrastructure within the River Road service area.
- A bioretention calculation was completed to estimate the total amount of capture within the subcatchments and the area of green infrastructure that would be required.

River Road WWTP

- Treatment alternatives:
 - CoMag®
 - ACTIFLO®
 - High Rate Filtration
- Increase plant capacity to 35 MGD:
 - Bypass WWF from rotary screens
 - Install new 35 MGD secondary treatment and chlorine contact tank in footprint of secondary clarifiers
 - Temporary chemical dosing of one secondary clarifier during construction

	Number of Overflows		Total CSO Volume (Mgal)	
	Existing	35 MGD Plant	Existing	35 MGD Plant
JOSO (003A)	61	61	95	95
River Road (002A)	60	42	190	91

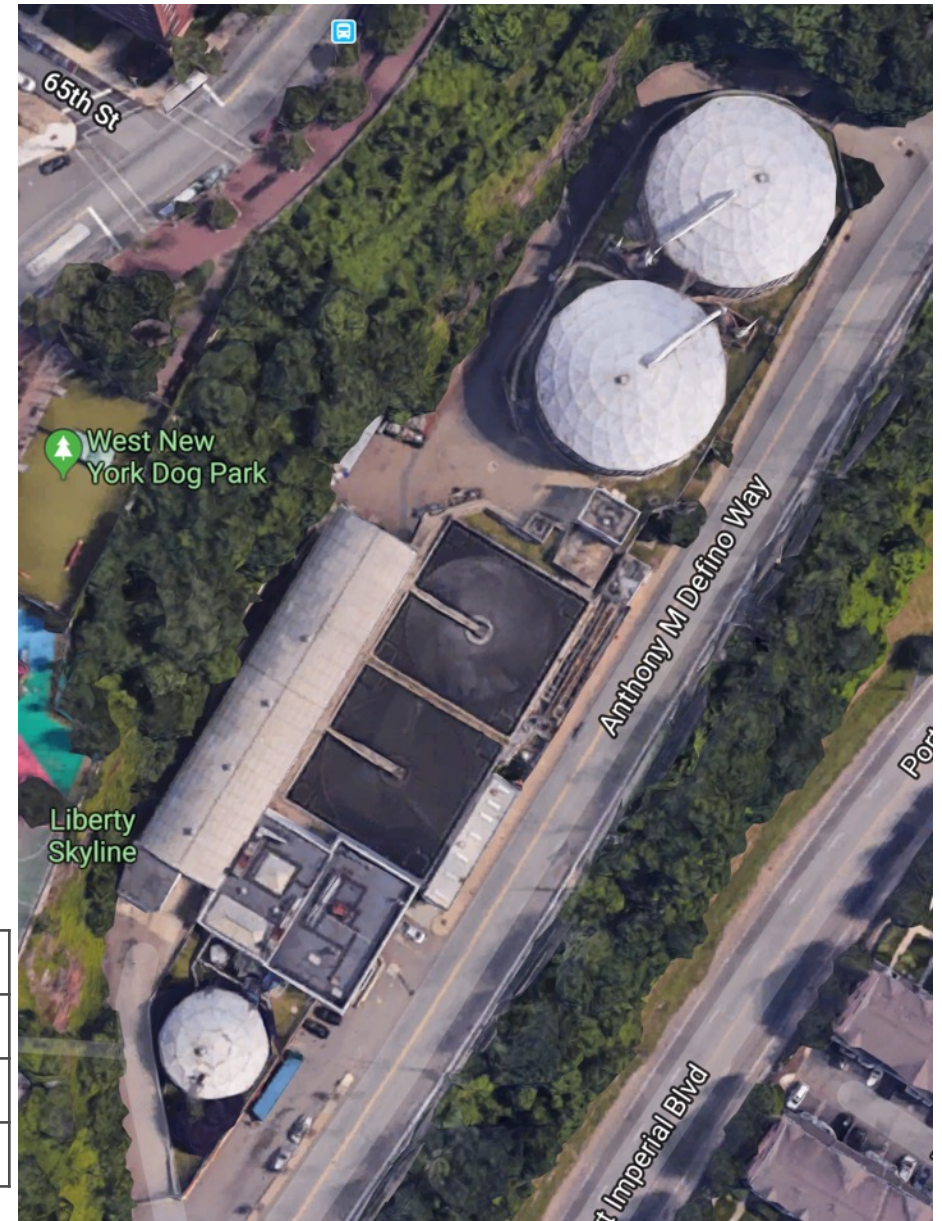

River Road WWTP

AquaPrime

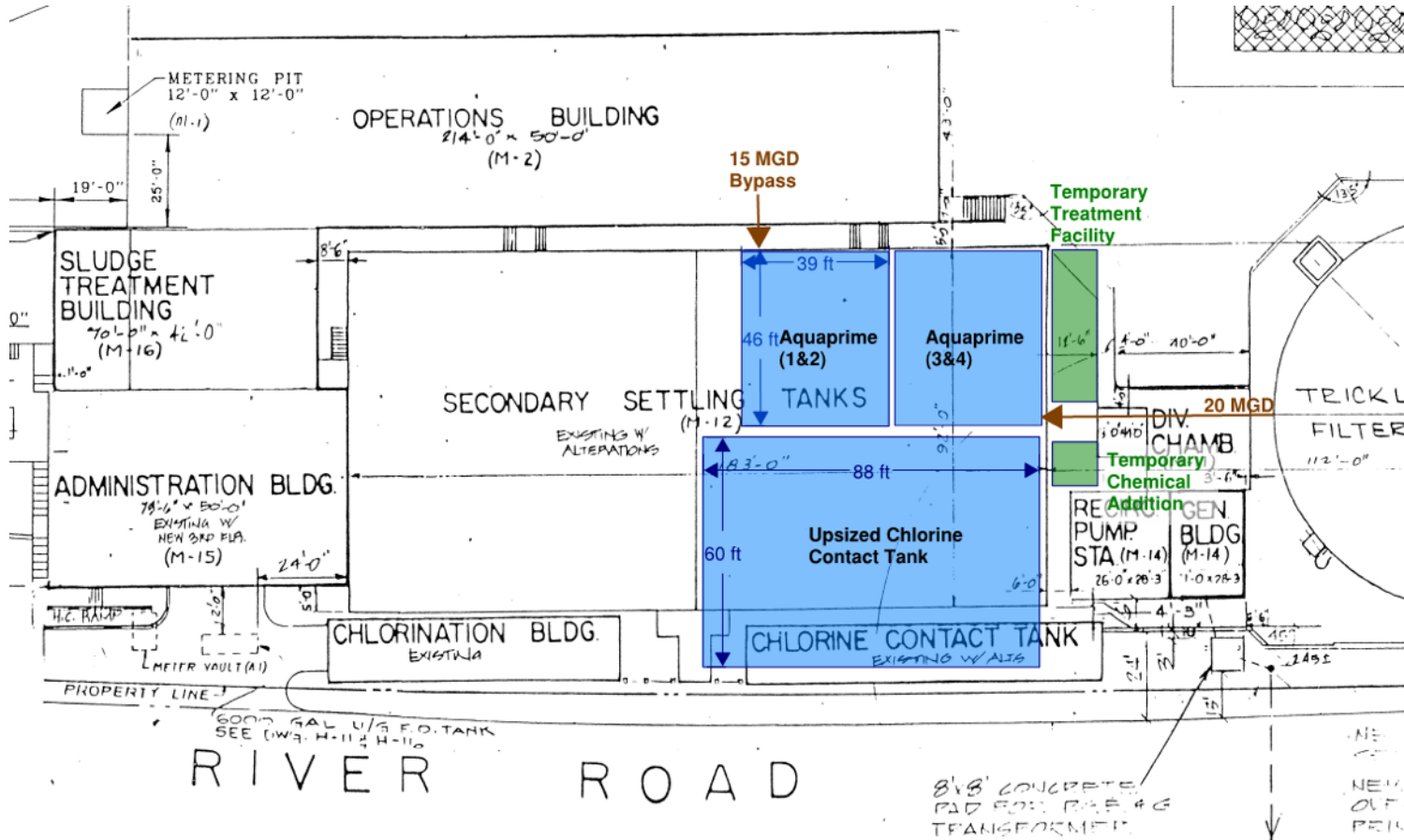

- Cloth media
- On-site jar/pilot testing required

Next Steps

Next Steps

- Finalize and submit Development and Evaluation of Alternatives Reports to NJDEP
- Proceed with developing Long Term Control Plans
- Continue ongoing dialogue and solicit feedback from the public

Thank You

